

Gipson

Heating and Cooling Products



COOLING/HEATING FAN COIL UNITS

Badban Tahviah Parsian Co.

2022-23 General Catalogue
Commercial Air Conditioning

Nomenclature	4 - 5
Technical Data	6 - 36
ACLA Series	7 - 9
ACLS Series	10 - 12
ACMP Series	13 - 15
ACMH Series	16 - 21
ACHA Series	22 - 27
ACSV Series	28 - 30
AFSG Series	31 - 33
AFSC Series	34 - 36
Performance Data	37 - 57
Dimension	58 - 69
Accessories	70 - 72

INDEX



Nomenclature

A CLS 020 L 2



Unit Type

2 = Two Pipe
4 = Four Pipe

Pipe Connection

L = Left
R = Right

Unit Size - Air Flow Rate (CFM)

020 = 200	080 = 800	160 = 1600
030 = 300	100 = 1000	180 = 1800
040 = 400	120 = 1200	200 = 2000
060 = 600	140 = 1400	

Component

CLA , CLS =
Ceiling Concealed non Duct (low static) Unit
CMP , CMH =
Ceiling Concealed Duct (middle static) Unit
CHA = Ceiling Concealed Duct (high static) Unit
CSV = One-Way Ceiling Cassette Unit
CST = Two-Way Ceiling Cassette Unit
CSF = Four-Way Ceiling Cassette Unit
FSG = Glass Floor Standing Unit
FSC = Concealed Floor Standing Unit

Family

A = GIPSON Fan Coil Unit



Technical Data

Low Static Model

ACLA020L2-ACLA100L2



Model No.			ACLA020L2	ACLA030L2	ACLA040L2	
Air flow rate	H/M/L	CFM	200/150/100	300/250/150	400/350/200	
Capacity	Cooling	H/M/L	KW	1.8	2.61	3.6
			BTU/hr	6,100	8,900	12,300
	Heating	H/M/L	KW	2.55	3.64	4.74
			BTU/hr	8,700	12,400	16,200
Water flow rate		gpm	1.5	2	2.5	
Water pressure drop		kPa	4.6	8.7	14.5	
Coil	Tube size	inch	3/8			
	Number of row	-	3			
	Number of tubes for row	-	8			
	Fin Per Inch	FPI	12			
Fan	Type	-	Forward centrifugal			
	Material	-	Galvanized steel			
	Number	-	1	2		
	External static pressure	Pa	25			
	Number of motor	-	1			
Pipe connection	Inlet	inch - mm	¾ - 25			
	Outlet	inch - mm	¾ - 25			
	Drain	inch - mm	½ - 16			
Drain pan	Type	-	Internal			
	Material	-	ABS high heat			
	Insulator	-	Elastomeric			
Filter	Type	-	Washable			
	Material	-	Polypropylene			
Fresh air intake hole		inch - mm	4 - 110			
Sound pressure level	Max	dB(A)	40			
Rated current		A	1x 0.55			
Power supply		PH, V, Hz	1, 220, 50			
Dimension	WxHxD	mm	645x220x520	745x220x520	845x220x520	

- Cooling design condition; inlet / outlet water temp: 7 °C (45 °F) / 12 °C (54 °F) and inlet air temp; DB=27 °C (80 °F), WB=20 °C (67 °F), sea level: 4000 ft

- Heating design condition; inlet water temp: 60 °C (140 °F) and inlet air temp: 27 °C (80 °F), sea level: 4000 ft

- Measuring sound pressure level at high speed mode at 2m away and ±2dB tolerance.

- Fan coil pipes connection side can be selected by the customer.

According to our innovation policy, some specifications may be change without prior notification.

Ceiling Concealed Series

Model No.			ACLA060L2	ACLA080L2	ACLA100L2	
Air flow rate	H/M/L	CFM	600/500/200	800/600/400	1000/600/400	
Capacity	Cooling	H/M/L	KW	5.13	7.03	8.89
			BTU/hr	17,500	24,000	30,300
	Heating	H/M/L	KW	6.68	8.87	11.1
			BTU/hr	22,800	30,300	37900
Water flow rate		gpm	3.5	5	6	
Water pressure drop		kPa	29.3	64	105	
Coil	Tube size	inch	3/8			
	Number of row	-	3			
	Number of tubes for row	-	8			
	Fin Per Inch	FPI	12			
Fan	Type	-	Forward centrifugal			
	Material	-	Galvanized steel			
	Number	-	2	3		
	External static pressure	Pa	25			
	Number of motor	-	1	2		
Pipe connection	Inlet	inch - mm	3/4 - 25			
	Outlet	inch - mm	3/4 - 25			
	Drain	inch - mm	1/2 - 16			
Drain pan	Type	-	Internal			
	Material	-	ABS high heat	Galvanized steel with electrostatic powder coated		
	Insulator	-	Elastomeric			
Filter	Type	-	Washable			
	Material	-	Polypropylene			
Fresh air intake hole		inch - mm	4 - 110			
Sound pressure level	Max	dB(A)	40	42		
Rated current		A	1x 0.55	2x 0.55		
Power supply		PH, V, Hz	1, 220, 50			
Dimension	WxHxD	mm	945x220x520	1195x220x520	1445x220x520	

- Cooling design condition; inlet / outlet water temp: 7 °C (45 °F) / 12 °C (54 °F) and inlet air temp: DB=27 °C (80 °F) , WB=20 °C (67 °F) , sea level: 4000 ft

- Heating design condition; inlet water temp: 60 °C (140 °F) and inlet air temp: 27 °C (80 °F) , sea level: 4000 ft

- Measuring sound pressure level at high speed mode at 2m away and ±2dB tolerance.

- Fan coil pipes connection side can be selected by the customer.

Low Static Model

ACLS020L2-ACLS100L2



Ceiling Concealed Series

Model No.			ACLS020L2	ACLS030L2	ACLS040L2	
Air flow rate	H/M/L	CFM	200/150/100	300/250/150	400/350/200	
Capacity	Cooling	H/M/L	KW	1.8	2.61	3.6
			BTU/hr	6,100	8,900	12,300
	Heating	H/M/L	KW	2.55	3.64	4.74
			BTU/hr	8,700	12,400	16,200
Water flow rate		gpm	1.5	2	2.5	
Water pressure drop		kPa	4.6	8.7	14.5	
Coil	Tube size	inch	3/8			
	Number of row	-	3			
	Number of tubes for row	-	8			
	Fin Per Inch	FPI	12			
Fan	Type	-	Forward centrifugal			
	Material	-	Galvanized steel			
	Number	-	1	2		
	External static pressure	Pa	25			
	Number of motor	-	1			
Pipe connection	Inlet	inch - mm	¾ - 25			
	Outlet	inch - mm	¾ - 25			
	Drain	inch - mm	½ - 16			
Drain pan	Type	-	Internal			
	Material	-	ABS high heat			
	Insulator	-	Elastomeric			
Filter	Type	-	Washable			
	Material	-	Polypropylene			
Fresh air intake hole		inch - mm	4 - 110			
Sound pressure level	Max	dB(A)	40			
Rated current		A	1x 0.55			
Power supply		PH , V , Hz	1 , 220 , 50			
Dimension	WxHxD	mm	645x180x520	745x180x520	845x180x520	

- Cooling design condition; inlet / outlet water temp: 7 °C (45 °F) / 12 °C (54 °F) and inlet air temp: DB=27 °C (80 °F) , WB=20 °C (67 °F) , sea level: 4000 ft

- Heating design condition; inlet water temp: 60 °C (140 °F) and inlet air temp: 27 °C (80 °F) , sea level: 4000 ft

- Measuring sound pressure level at high speed mode at 2m away and ±2dB tolerance.

- Fan coil pipes connection side can be selected by the customer.

According to our innovation policy, some specifications may be change without prior notification.

Ceiling Concealed Series

Model No.			ACLS060L2	ACLS080L2	ACLS100L2	
Air flow rate	H/M/L	CFM	600/500/200	800/600/400	1000/600/400	
Capacity	Cooling	H/M/L	KW	5.13	7.03	8.89
			BTU/hr	17,500	24,000	30,300
	Heating	H/M/L	KW	6.68	8.87	11.1
			BTU/hr	22,800	30,300	37900
Water flow rate		gpm	3.5	5	6	
Water pressure drop		kPa	29.3	64	105	
Coil	Tube size	inch	3/8			
	Number of row	-	3			
	Number of tubes for row	-	8			
	Fin Per Inch	FPI	12			
Fan	Type	-	Forward centrifugal			
	Material	-	Galvanized steel			
	Number	-	2	3		
	External static pressure	Pa	25			
	Number of motor	-	1	2		
Pipe connection	Inlet	inch - mm	¾ - 25			
	Outlet	inch - mm	¾ - 25			
	Drain	inch - mm	½ - 16			
Drain pan	Type	-	Internal			
	Material	-	ABS high heat	Galvanized steel with electrostatic powder coated		
	Insulator	-	Elastomeric			
Filter	Type	-	Washable			
	Material	-	Polypropylene			
Fresh air intake hole		inch - mm	4 - 110			
Sound pressure level	Max	dB(A)	40	42		
Rated current		A	1x 0.55	2x 0.55		
Power supply		PH , V , Hz	1 , 220 , 50			
Dimension	WxHxD	mm	945x180x520	1195x180x520	1445x180x520	

- Cooling design condition; inlet / outlet water temp: 7 °C (45 °F) / 12 °C (54 °F) and inlet air temp; DB=27 °C (80 °F) , WB=20 °C (67 °F) , sea level: 4000 ft
- Heating design condition; inlet water temp: 60 °C (140 °F) and inlet air temp: 27 °C (80 °F) , sea level: 4000 ft
- Measuring sound pressure level at high speed mode at 2m away and ±2dB tolerance.
- Fan coil pipes connection side can be selected by the customer.

Middle Static Model

ACMP020L2-ACMP100L2



Ceiling Concealed Series

Model No.			ACMP020L2	ACMP030L2	ACMP040L2	
Air flow rate	H/M/L	CFM	200/150/100	300/250/150	400/350/200	
Capacity	Cooling	H/M/L	KW	1.8	2.61	3.6
			BTU/hr	6,100	8,900	12,300
	Heating	H/M/L	KW	2.55	3.64	4.74
			BTU/hr	8,700	12,400	16,200
Water flow rate		gpm	1.5	2	2.5	
Water pressure drop		kPa	4.6	8.7	14.5	
Coil	Tube size	inch	3/8			
	Number of row	-	3			
	Number of tubes for row	-	8			
	Fin Per Inch	FPI	12			
Fan	Type	-	Forward centrifugal			
	Material	-	Galvanized steel			
	Number	-	1	2		
	External static pressure	Pa	40			
	Number of motor	-	1			
Pipe connection	Inlet	inch - mm	¾ - 25			
	Outlet	inch - mm	¾ - 25			
	Drain	inch - mm	½ - 16			
Drain pan	Type	-	Internal			
	Material	-	ABS high heat			
	Insulator	-	Elastomeric			
Filter	Type	-	Washable			
	Material	-	Polypropylene			
Fresh air intake hole		inch - mm	4 - 110			
Sound pressure level	Max	dB(A)	40			
Rated current		A	1x 0.55			
Power supply		PH , V , Hz	1 , 220 , 50			
Dimension	WxHxD	mm	645x220x350	745x220x350	845x220x350	

- Cooling design condition; inlet / outlet water temp: 7 °C (45 °F) / 12 °C (54 °F) and inlet air temp; DB=27 °C (80 °F) , WB=20 °C (67 °F) , sea level: 4000 ft
- Heating design condition; inlet water temp: 60 °C (140 °F) and inlet air temp: 27 °C (80 °F) , sea level: 4000 ft
- Measuring sound pressure level at high speed mode at 2m away and ±2dB tolerance.
- Fan coil pipes connection side can be selected by the customer.

According to our innovation policy, some specifications may be change without prior notification.

Ceiling Concealed Series

Model No.			ACMP060L2	ACMP080L2	ACMP100L2	
Air flow rate	H/M/L	CFM	600/500/200	800/600/400	1000/600/400	
Capacity	Cooling	H/M/L	KW	5.13	7.03	8.89
			BTU/hr	17,500	24,000	30,300
	Heating	H/M/L	KW	6.68	8.87	11.1
			BTU/hr	22,800	30,300	37900
Water flow rate		gpm	3.5	5	6	
Water pressure drop		kPa	29.3	64	105	
Coil	Tube size	inch	3/8			
	Number of row	-	3			
	Number of tubes for row	-	8			
	Fin Per Inch	FPI	12			
Fan	Type	-	Forward Centrifugal			
	Material	-	Galvanized Steel			
	Number	-	2	3		
	External static pressure	Pa	40			
	Number of motor	-	1	2		
Pipe connection	Inlet	inch - mm	¾ - 25			
	Outlet	inch - mm	¾ - 25			
	Drain	inch - mm	½ - 16			
Drain pan	Type	-	Internal			
	Material	-	ABS high heat	Galvanized steel with electrostatic powder coated		
	Insulator	-	Elastomeric			
Filter	Type	-	Washable			
	Material	-	Polypropylene			
Fresh air intake hole		inch - mm	4 - 110			
Sound pressure level	Max	dB(A)	40	42		
Rated current		A	1x 0.55	2x 0.55		
Power supply		PH , V , Hz	1 , 220 , 50			
Dimension	WxHxD	mm	945x220x350	1195x220x350	1445x220x350	

- Cooling design condition; inlet / outlet water temp: 7 °C (45 °F) / 12 °C (54 °F) and inlet air temp; DB=27 °C (80 °F) , WB=20 °C (67 °F) , sea level: 4000 ft

- Heating design condition; inlet water temp: 60 °C (140 °F) and inlet air temp: 27 °C (80 °F) , sea level: 4000 ft

- Measuring sound pressure level at high speed mode at 2m away and ±2dB tolerance.

- Fan coil pipes connection side can be selected by the customer.

Ceiling Concealed Series

Model No.			ACMP020L2	ACMP030L2	ACMP040L2	
Air flow rate	H/M/L	CFM	200/150/100	300/250/150	400/350/200	
Capacity	Cooling	H/M/L	KW	1.8	2.61	3.6
			BTU/hr	6,100	8,900	12,300
	Heating	H/M/L	KW	2.55	3.64	4.74
			BTU/hr	8,700	12,400	16,200
Water flow rate		gpm	1.5	2	2.5	
Water pressure drop		kPa	4.6	8.7	14.5	
Coil	Tube size	inch	3/8			
	Number of row	-	3			
	Number of tubes for row	-	8			
	Fin Per Inch	FPI	12			
Fan	Type	-	Forward centrifugal			
	Material	-	Galvanized steel			
	Number	-	1	2		
	External static pressure	Pa	40			
	Number of motor	-	1			
Pipe connection	Inlet	inch - mm	¾ - 25			
	Outlet	inch - mm	¾ - 25			
	Drain	inch - mm	½ - 16			
Drain pan	Type	-	Internal			
	Material	-	ABS high heat			
	Insulator	-	Elastomeric			
Filter	Type	-	Washable			
	Material	-	Polypropylene			
Fresh air intake hole		inch - mm	4 - 110			
Sound pressure level	Max	dB(A)	40			
Rated current		A	1x 0.55			
Power supply		PH, V, Hz	1, 220, 50			
Dimension	WxHxD	mm	645x220x350	745x220x350	845x220x350	

- Cooling design condition; inlet / outlet water temp: 7 °C (45 °F) / 12 °C (54 °F) and inlet air temp; DB=27 °C (80 °F) , WB=20 °C (67 °F) , sea level: 4000 ft

- Heating design condition; inlet water temp: 60 °C (140 °F) and inlet air temp: 27 °C (80 °F) , sea level: 4000 ft

- Measuring sound pressure level at high speed mode at 2m away and ±2dB tolerance.

- Fan coil pipes connection side can be selected by the customer.

According to our innovation policy, some specifications may be change without prior notification.

Ceiling Concealed Series

Model No.			ACMP060L2	ACMP080L2	ACMP100L2	
Air flow rate	H/M/L	CFM	600/500/200	800/600/400	1000/600/400	
Capacity	Cooling	H/M/L	KW	5.13	7.03	8.89
			BTU/hr	17,500	24,000	30,300
	Heating	H/M/L	KW	6.68	8.87	11.1
			BTU/hr	22,800	30,300	37900
Water flow rate		gpm	3.5	5	6	
Water pressure drop		kPa	29.3	64	105	
Coil	Tube size	inch	3/8			
	Number of row	-	3			
	Number of tubes for row	-	8			
	Fin Per Inch	FPI	12			
Fan	Type	-	Forward Centrifugal			
	Material	-	Galvanized Steel			
	Number	-	2	3		
	External static pressure	Pa	40			
	Number of motor	-	1	2		
Pipe connection	Inlet	inch - mm	¾ - 25			
	Outlet	inch - mm	¾ - 25			
	Drain	inch - mm	½ - 16			
Drain pan	Type	-	Internal			
	Material	-	ABS high heat	Galvanized steel with electrostatic powder coated		
	Insulator	-	Elastomeric			
Filter	Type	-	Washable			
	Material	-	Polypropylene			
Fresh air intake hole		inch - mm	4 - 110			
Sound pressure level	Max	dB(A)	40	42		
Rated current		A	1x 0.55	2x 0.55		
Power supply		PH , V , Hz	1 , 220 , 50			
Dimension	WxHxD	mm	945x220x350	1195x220x350	1445x220x350	

- Cooling design condition; inlet / outlet water temp: 7 °C (45 °F) / 12 °C (54 °F) and inlet air temp: DB=27 °C (80 °F) , WB=20 °C (67 °F) , sea level: 4000 ft

- Heating design condition; inlet water temp: 60 °C (140 °F) and inlet air temp: 27 °C (80 °F) , sea level: 4000 ft

- Measuring sound pressure level at high speed mode at 2m away and ±2dB tolerance.

- Fan coil pipes connection side can be selected by the customer.

Middle Static Model

ACMH020L2-ACMH100L2



Model No.			ACMH020L2	ACMH030L2	ACMH040L2	
Air flow rate	H/M/L	CFM	200/150/100	300/250/150	400/350/200	
Capacity	Cooling	H/M/L	KW	1.8	2.61	3.6
			BTU/hr	6,100	8,900	12,300
	Heating	H/M/L	KW	2.55	3.64	4.74
			BTU/hr	8,700	12,400	16,200
Water flow rate		gpm	1.5	2	2.5	
Water pressure drop		kPa	4.6	8.7	14.5	
Coil	Tube size	inch	3/8			
	Number of row	-	3			
	Number of tubes for row	-	8			
	Fin Per Inch	FPI	12			
Fan	Type	-	Forward centrifugal			
	Material	-	Galvanized steel			
	Number	-	1	2		
	External static pressure	Pa	40			
	Number of motor	-	1			
Pipe connection	Inlet	inch - mm	¾ - 25			
	Outlet	inch - mm	¾ - 25			
	Drain	inch - mm	½ - 16			
Drain pan	Type	-	Internal			
	Material	-	ABS high heat			
	Insulator	-	Elastomeric			
Filter	Type	-	Washable			
	Material	-	Polypropylene			
Fresh air intake hole		inch - mm	4 - 110			
Sound pressure level	Max	dB(A)	40			
Rated current		A	1x 0.55			
Power supply		PH, V, Hz	1, 220, 50			
Dimension	WxHxD	mm	645x220x520	745x220x520	845x220x520	

- Cooling design condition; inlet / outlet water temp: 7 °C (45 °F) / 12 °C (54 °F) and inlet air temp; DB=27 °C (80 °F) , WB=20 °C (67 °F) , sea level: 4000 ft

- Heating design condition; inlet water temp: 60 °C (140 °F) and inlet air temp: 27 °C (80 °F) , sea level: 4000 ft

- Measuring sound pressure level at high speed mode at 2m away and ±2dB tolerance.

- Fan coil pipes connection side can be selected by the customer.

According to our innovation policy, some specifications may be change without prior notification.

Ceiling Concealed Series

Model No.			ACMH060L2	ACMH080L2	ACMH100L2	
Air flow rate	H/M/L	CFM	600/500/200	800/600/400	1000/600/400	
Capacity	Cooling	H/M/L	KW	5.13	7.03	8.89
			BTU/hr	17,500	24,000	30,300
	Heating	H/M/L	KW	6.68	8.87	11.1
			BTU/hr	22,800	30,300	37900
Water flow rate		gpm	3.5	5	6	
Water pressure drop		kPa	29.3	64	105	
Coil	Tube size	inch	3/8			
	Number of row	-	3			
	Number of tubes for row	-	8			
	Fin Per Inch	FPI	12			
Fan	Type	-	Forward centrifugal			
	Material	-	Galvanized steel			
	Number	-	2	3		
	External static pressure	Pa	40			
	Number of motor	-	1	2		
Pipe connection	Inlet	inch - mm	¾ - 25			
	Outlet	inch - mm	¾ - 25			
	Drain	inch - mm	½ - 16			
Drain pan	Type	-	Internal			
	Material	-	ABS high heat	Galvanized steel with electrostatic powder coated		
	Insulator	-	Elastomeric			
Filter	Type	-	Washable			
	Material	-	Polypropylene			
Fresh air intake hole		inch - mm	4 - 110			
Sound pressure level	Max	dB(A)	40	42		
Rated current		A	1x 0.55	2x 0.55		
Power supply		PH , V , Hz	1 , 220 , 50			
Dimension	WxHxD	mm	945x220x520	1195x220x520	1445x220x520	

- Cooling design condition; inlet / outlet water temp: 7 °C (45 °F) / 12 °C (54 °F) and inlet air temp; DB=27 °C (80 °F) , WB=20 °C (67 °F) , sea level: 4000 ft

- Heating design condition; inlet water temp: 60 °C (140 °F) and inlet air temp: 27 °C (80 °F) , sea level: 4000 ft

- Measuring sound pressure level at high speed mode at 2m away and ±2dB tolerance.

- Fan coil pipes connection side can be selected by the customer.

Middle Static Model

ACMH020L4-ACMH100L4



Model No.			ACMH020L4	ACMH030L4	ACMH040L4		
Air flow rate		H/M/L	CFM	200/150/100	300/250/150	400/350/200	
Capacity	Cooling	H/M/L	KW	1.8	2.61	3.6	
			BTU/hr	6,100	8,900	12,300	
	Heating	H/M/L	KW	1.15	1.62	2.08	
			BTU/hr	3,900	5,500	7,100	
Water flow rate			gpm	1.5	2	2.5	
Water pressure drop		Cooling		kPa	4.6	8.7	14.5
		Heating		kPa	1.8	2	4
Cooling	Coil	Tube size		inch	3/8		
		Number of row		-	3		
		Number of tubes for row		-	8		
		Fin Per Inch		FPI	12		
Heating	Coil	Tube size		inch	3/8		
		Number of row		-	1		
		Number of tubes for row		-	8		
		Fin Per Inch		FPI	12		
Fan		Type		-	Forward centrifugal		
		Material		-	Galvanized steel		
		Number		-	1	2	
		External static pressure		Pa	35		
		Number of motor		-	1		
Pipe connection		Inlet		inch - mm	¾ - 25		
		Outlet		inch - mm	¾ - 25		
		Drain		inch - mm	½ - 16		
Drain pan		Type		-	Internal		
		Material		-	ABS high heat		
		Insulator		-	Elastomeric		
Filter		Type		-	Washable		
		Material		-	Polypropylene		
Fresh air intake hole			inch - mm	4 - 110			
Sound pressure level		Max	dB(A)	40			
Rated current			A	1x 0.55			
Power supply			PH, V, Hz	1, 220, 50			
Dimension		WxHxD	mm	645x220x520	745x220x520	845x220x520	

- Cooling design condition; inlet / outlet water temp: 7 °C (45 °F) / 12 °C (54 °F) and inlet air temp; DB=27 °C (80 °F), WB=20 °C (67 °F), sea level: 4000 ft

- Heating design condition; inlet water temp: 60 °C (140 °F) and inlet air temp: 27 °C (80 °F), sea level: 4000 ft

- Measuring sound pressure level at high speed mode at 2m away and ±2dB tolerance.

- Fan coil pipes connection side can be selected by the customer.

Model No.			ACMH060L4	ACMH080L4	ACMH100L4	
Air flow rate		H/M/L	CFM	600/500/200	800/600/400	1000/600/400
Capacity	Cooling	H/M/L	KW	5.13	7.03	8.89
			BTU/hr	17,500	24,000	30,300
	Heating	H/M/L	KW	2.87	3.9	4.89
			BTU/hr	9,800	13,300	16,700
Water flow rate			gpm	3.5	5	6
Water pressure drop		Cooling	kPa	29.3	64	105
		Heating	kPa	8	19	31.3
Cooling	Coil	Tube size	inch	3/8		
		Number of row	-	3		
		Number of tubes for row	-	8		
		Fin Per Inch	FPI	12		
Heating	Coil	Tube size	inch	3/8		
		Number of row	-	1		
		Number of tubes for row	-	8		
		Fin Per Inch	FPI	12		
Fan	Type	-	Forward centrifugal			
	Material	-	Galvanized steel			
	Number	-	2	3		
	External static pressure	Pa	35			
	Number of motor	-	1	2		
Pipe connection		Inlet	inch - mm	3/4 - 25		
		Outlet	inch - mm	3/4 - 25		
		Drain	inch - mm	1/2 - 16		
Drain pan		Type	-	Internal		
		Material	-	ABS high heat	Galvanized steel with electrostatic powder coated	
		Insulator	-	Elastomeric		
Filter		Type	-	Washable		
		Material	-	Polypropylene		
Fresh air intake hole			inch - mm	4 - 110		
Sound pressure level		Max	dB(A)	41	43	
Rated current			A	1x 0.55	2x 0.55	
Power supply			PH , V , Hz	1 , 220 , 50		
Dimension		WxHxD	mm	945x220x520	1195x220x520	1445x220x520

- Cooling design condition; inlet / outlet water temp: 7 °C (45 °F) / 12 °C (54 °F) and inlet air temp; DB=27 °C (80 °F) , WB=20 °C (67 °F) , sea level: 4000 ft

- Heating design condition; inlet water temp: 60 °C (140 °F) and inlet air temp: 27 °C (80 °F) , sea level: 4000 ft

- Measuring sound pressure level at high speed mode at 2m away and ±2dB tolerance.

- Fan coil pipes connection side can be selected by the customer.

High Static Model

ACHA060L2-ACHA200L2



Model No.			ACHA060L2	ACHA080L2	ACHA100L2	ACHA120L2	
Air flow rate	H/M/L	CFM	600/450/300	800/600/400	1000/600/450	1200/800/650	
Capacity	Cooling	H/M/L	KW	5.12	6.57	8.33	9.65
		BTU/hr	17,500	22,400	28,400	33,000	
	Heating	H/M/L	KW	7.77	9.83	12.18	14.07
		BTU/hr	26,500	33,500	41,600	48,000	
Water flow rate		gpm	3	4	5	6	
Water pressure drop		kPa	6.7	11.2	18.4	25.4	
Coil	Tube size	inch	3/8				
	Number of row	-	4				
	Number of tubes for row	-	12				
	Fin Per Inch	FPI	12				
Fan	Type	-	Forward centrifugal				
	Material	-	Galvanized steel				
	Number	-	2				
	External static pressure	Pa	120				
	Number of motor	-	1				
Pipe connection	Inlet	inch - mm	1 - 32				
	Outlet	inch - mm	1 - 32				
	Drain	inch - mm	1/2 - 22				
Drain pan	Type	-	Internal				
	Material	-	Galvanized steel with electrostatic powder coated				
	Insulator	-	Elastomeric				
Filter	Type	-	Washable				
	Material	-	Polypropylene				
Fresh air intake hole		inch - mm	4 - 110				
Sound pressure level	Max	dB(A)	47	50	51		
Input power		W	1x 250 - 450				
Power supply		PH, V, Hz	1, 220, 50				
Dimension	WxHxD	mm	845x320x750			945x320x750	

- Cooling design condition; inlet / outlet water temp: 7 °C (45 °F) / 12 °C (54 °F) and inlet air temp; DB=27 °C (80 °F), WB=20 °C (67 °F), sea level: 4000 ft

- Heating design condition; inlet water temp: 60 °C (140 °F) and inlet air temp: 27 °C (80 °F), sea level: 4000 ft

- Measuring sound pressure level at high speed mode at 2m away and ±2dB tolerance.

- Fan coil pipes connection side can be selected by the customer.

Model No.			ACHA140L2	ACHA160L2	ACHA180L2	ACHA200L2	
Air flow rate	H/M/L	CFM	1400/1000/800	1600/1200/1000	1800/1400/1200	2000/1600/1400	
Capacity	Cooling	H/M/L	KW	12.06	13.99	15.82	17.77
			BTU/hr	41,200	47,700	54,000	60,600
	Heating	H/M/L	KW	17.05	19.26	21.95	24.15
			BTU/hr	58,200	65,800	74,900	82,500
Water flow rate		gpm	7	9	9	11	
Water pressure drop		kPa	41.43	64.65	77.14	110	
Coil	Tube size	inch	3/8				
	Number of row	-	4				
	Number of tubes for row	-	12				
	Fin Per Inch	FPI	12				
Fan	Type	-	Forward centrifugal				
	Material	-	Galvanized steel				
	Number	-	2	3			
	External static pressure	Pa	120				
	Number of motor	-	1	2			
Pipe connection	Inlet	inch - mm	1 - 32				
	Outlet	inch - mm	1 - 32				
	Drain	inch - mm	1/2 - 22				
Drain pan	Type	-	Internal				
	Material	-	Galvanized steel with electrostatic powder coated				
	Insulator	-	Elastomeric				
Filter	Type	-	Washable				
	Material	-	Polypropylene				
Fresh air intake hole		inch - mm	4 - 110				
Sound pressure level	Max	dB(A)	53	55	57		
Input power		W	1x 250 - 450		2x 250 - 450		
Power supply		PH , V , Hz	1 , 220 , 50				
Dimension	WxHxD	mm	1195x320x750		1445x320x750		

- Cooling design condition; inlet / outlet water temp: 7 °C (45 °F) / 12 °C (54 °F) and inlet air temp; DB=27 °C (80 °F) , WB=20 °C (67 °F) , sea level: 4000 ft

- Heating design condition; inlet water temp: 60 °C (140 °F) and inlet air temp: 27 °C (80 °F) , sea level: 4000 ft

- Measuring sound pressure level at high speed mode at 2m away and ±2dB tolerance.

- Fan coil pipes connection side can be selected by the customer.

High Static Model

ACHA060L4-ACHA200L4



Model No.			ACHA060L4	ACHA080L4	ACHA100L4	ACHA120L4	
Air flow rate	H/M/L	CFM	600/450/300	800/600/400	1000/600/450	1200/800/650	
Capacity	Cooling	H/M/L	KW	5.12	6.57	8.33	9.65
		BTU/hr	17,500	22,400	28,400	33,000	
	Heating	H/M/L	KW	5.28	6.54	8.07	9.2
		BTU/hr	18,000	22,300	27,500	31,400	
Water flow rate		gpm	3	4	5	6	
Water pressure drop	Cooling		kPa	6.7	11.2	18.4	25.4
	Heating		kPa	2.4	4.1	6.7	9.2
Cooling	Coil	Tube size	inch	3/8			
		Number of row	-	4			
		Number of tubes for row	-	12			
		Fin Per Inch	FPI	12			
Heating	Coil	Tube size	inch	3/8			
		Number of row	-	2			
		Number of tubes for row	-	12			
		Fin Per Inch	FPI	12			
Fan	Type	-	Forward centrifugal				
	Material	-	Galvanized steel				
	Number	-	2				
	External static pressure	Pa	100				
	Number of motor	-	1				
Pipe connection	Inlet	inch - mm	1 - 32				
	Outlet	inch - mm	1 - 32				
	Drain	inch - mm	1/2 - 22				
Drain pan	Type	-	Internal				
	Material	-	Galvanized steel with electrostatic powder coated				
	Insulator	-	Elastomeric				
Filter	Type	-	Washable				
	Material	-	Polypropylene				
Fresh air intake hole		inch - mm	4 - 110				
Sound pressure level	Max	dB(A)	47	51	53		
Input power		W	1x 250 - 450				
Power supply		PH, V, Hz	1, 220, 50				
Dimension	WxHxD	mm	845x320x750		945x320x750		

- Cooling design condition; inlet / outlet water temp: 7 °C (45 °F) / 12 °C (54 °F) and inlet air temp; DB=27 °C (80 °F) , WB=20 °C (67 °F) , sea level: 4000 ft

- Heating design condition; inlet water temp: 60 °C (140 °F) and inlet air temp: 27 °C (80 °F) , sea level: 4000 ft

- Measuring sound pressure level at high speed mode at 2m away and ±2dB tolerance.

- Fan coil pipes connection side can be selected by the customer.

Model No.			ACHA140L4	ACHA160L4	ACHA180L4	ACHA200L4		
Air flow rate		H/M/L	CFM	1400/1000/800	1600/1200/1000	1800/1400/1200	2000/1600/1400	
Capacity	Cooling	H/M/L	KW	12.06	13.99	15.82	17.77	
			BTU/hr	41,200	47,700	54,000	60,600	
	Heating	H/M/L	KW	11.31	12.62	14.55	15.86	
			BTU/hr	38,600	43,100	49,600	54,100	
Water flow rate			gpm	7	9	9	11	
Water pressure drop		Cooling		kPa	41.43	64.65	77.14	110
		Heating		kPa	15.2	23.6	28.4	40.4
Cooling	Coil	Tube size		inch	3/8			
		Number of row		-	4			
		Number of tubes for row		-	12			
		Fin Per Inch		FPI	12			
Heating	Coil	Tube size		inch	3/8			
		Number of row		-	2			
		Number of tubes for row		-	12			
		Fin Per Inch		FPI	12			
Fan		Type		-	Forward centrifugal			
		Material		-	Galvanized steel			
		Number		-	2	3		
		External static pressure		Pa	100			
		Number of motor		-	1	2		
Pipe connection		Inlet		inch - mm	1 - 32			
		Outlet		inch - mm	1 - 32			
		Drain		inch - mm	1/2 - 22			
Drain pan		Type		-	Internal			
		Material		-	Galvanized steel with electrostatic powder coated			
		Insulator		-	Elastomeric			
Filter		Type		-	Washable			
		Material		-	Polypropylene			
Fresh air intake hole			inch - mm	4 - 110				
Sound pressure level		Max	dB(A)	54	57	60		
Input power			W	1x 250 - 450		2x 250 - 450		
Power supply			PH, V, Hz	1, 220, 50				
Dimension		WxHxD	mm	1195x320x750		1445x320x750		

- Cooling design condition; inlet / outlet water temp: 7 °C (45 °F) / 12 °C (54 °F) and inlet air temp; DB=27 °C (80 °F), WB=20 °C (67 °F), sea level: 4000 ft

- Heating design condition; inlet water temp: 60 °C (140 °F) and inlet air temp: 27 °C (80 °F), sea level: 4000 ft

- Measuring sound pressure level at high speed mode at 2m away and ±2dB tolerance.

- Fan coil pipes connection side can be selected by the customer.

Ceiling Cassette Model

ACSV020L2-ACSV100L2



Model No.			ACSV020L2	ACSV030L2	ACSV040L2	
Air flow rate	H/M/L	CFM	200/150/100	300/250/150	400/350/200	
Capacity	Cooling	H/M/L	KW	1.8	2.61	3.6
			BTU/hr	6,100	8,900	12,300
	Heating	H/M/L	KW	2.55	3.64	4.74
			BTU/hr	8,700	12,400	16,200
Water flow rate		gpm	1.5	2	2.5	
Water pressure drop		kPa	4.6	8.7	14.5	
Coil	Tube size	inch	3/8			
	Number of row	-	3			
	Number of tubes for row	-	8			
	Fin Per Inch	FPI	12			
Fan	Type	-	Forward centrifugal			
	Material	-	Galvanized steel			
	Number	-	1	2		
	Number of motor	-	1			
Pipe connection	Inlet	inch - mm	¾ - 25			
	Outlet	inch - mm	¾ - 25			
	Drain	inch - mm	½ - 16			
Drain pan	Type	-	Internal			
	Material	-	ABS high heat			
	Insulator	-	Elastomeric			
Filter	Type	-	Washable			
	Material	-	Polypropylene			
Fresh air intake hole		inch - mm	4 - 110			
Sound pressure level	Max	dB(A)	41			
Rated current		A	1x 0.55			
Power supply		PH, V, Hz	1, 220, 50			
Dimension	Body	WxHxD	mm	650x270x400	750x270x400	850x270x400
	Decoration panel	WxHxD	mm	1000x20x520	1100x20x520	1200x20x520

- Cooling design condition; inlet / outlet water temp: 7 °C (45 °F) / 12 °C (54 °F) and inlet air temp; DB=27 °C (80 °F) , WB=20 °C (67 °F) , sea level: 4000 ft

- Heating design condition; inlet water temp: 60 °C (140 °F) and inlet air temp: 27 °C (80 °F) , sea level: 4000 ft

- Measuring sound pressure level at high speed mode at 2m away and ±2dB tolerance.

- Fan coil pipes connection side can be selected by the customer.

Model No.			ACSV060L2	ACSV080L2	ACSV100L2	
Air flow rate	H/M/L	CFM	600/500/200	800/600/400	1000/600/400	
Capacity	Cooling	H/M/L	KW	5.13	7.03	8.89
			BTU/hr	17,500	24,000	30,300
	Heating	H/M/L	KW	6.68	8.87	11.1
			BTU/hr	22,800	30,300	37900
Water flow rate		gpm	3.5	5	6	
Water pressure drop		kPa	29.3	64	105	
Coil	Tube size		inch	3/8		
	Number of row		-	3		
	Number of tubes for row		-	8		
	Fin Per Inch		FPI	12		
Fan	Type		-	Forward centrifugal		
	Material		-	Galvanized steel		
	Number		-	2	3	
	Number of motor		-	1	2	
Pipe connection	Inlet		inch - mm	¾ - 25		
	Outlet		inch - mm	¾ - 25		
	Drain		inch - mm	½ - 16		
Drain pan	Type		-	Internal		
	Material		-	ABS high heat	Galvanized steel with electrostatic powder coated	
	Insulator		-	Elastomeric		
Filter	Type		-	Washable		
	Material		-	Polypropylene		
Fresh air intake hole		inch - mm	4 - 110			
Sound pressure level	Max	dB(A)	41	42		
Rated current		A	1x 0.55	2x 0.55		
Power supply		PH , V , Hz	1 , 220 , 50			
Dimension	Body	WxHxD	mm	950x270x400	1200x270x400	1450x270x400
	Decoration panel	WxHxD	mm	1300x20x520	1550x20x520	1800x20x520

- Cooling design condition; inlet / outlet water temp: 7 °C (45 °F) / 12 °C (54 °F) and inlet air temp; DB=27 °C (80 °F) , WB=20 °C (67 °F) , sea level: 4000 ft

- Heating design condition; inlet water temp: 60 °C (140 °F) and inlet air temp: 27 °C (80 °F) , sea level: 4000 ft

- Measuring sound pressure level at high speed mode at 2m away and ±2dB tolerance.

- Fan coil pipes connection side can be selected by the customer.

Floor Standing Glass Model

AFSG020L2-AFSG100L2



Model No.			AFSG020L2	AFSG030L2	AFSG040L2	
Air flow rate	H/M/L	CFM	200/150/100	300/250/150	400/350/200	
Capacity	Cooling	H/M/L	KW	1.8	2.61	3.6
			BTU/hr	6,100	8,900	12,300
	Heating	H/M/L	KW	2.55	3.64	4.74
			BTU/hr	8,700	12,400	16,200
Water flow rate		gpm	1.5	2	2.5	
Water pressure drop		kPa	4.6	8.7	14.5	
Coil	Tube size	inch	3/8			
	Number of row	-	3			
	Number of tubes for row	-	8			
	Fin Per Inch	FPI	12			
Fan	Type	-	Forward centrifugal			
	Material	-	Galvanized steel			
	Number	-	1	2		
	Number of motor	-	1			
Pipe connection	Inlet	inch - mm	¾ - 25			
	Outlet	inch - mm	¾ - 25			
	Drain	inch - mm	½ - 16			
Drain pan	Type	-	Internal			
	Material	-	Galvanized steel with electrostatic powder coated			
	Insulator	-	Elastomeric			
Filter	Type	-	Washable			
	Material	-	Polypropylene			
Fresh air intake hole		inch - mm	4 - 110			
Sound pressure level	Max	dB(A)	41			
Rated current		A	1x 0.55			
Power supply		PH , V , Hz	1 , 220 , 50			
Dimension	WxHxD	mm	865x640x233	965x640x233	1065x640x233	

- Cooling design condition; inlet / outlet water temp: 7 °C (45 °F) / 12 °C (54 °F) and inlet air temp; DB=27 °C (80 °F) , WB=20 °C (67 °F) , sea level: 4000 ft

- Heating design condition; inlet water temp: 60 °C (140 °F) and inlet air temp: 27 °C (80 °F) , sea level: 4000 ft

- Measuring sound pressure level at high speed mode at 2m away and ±2dB tolerance.

- Fan coil pipes connection side can be selected by the customer.

Model No.			AFSG060L2	AFSG080L2	AFSG100L2	
Air flow rate	H/M/L	CFM	600/500/200	800/600/400	1000/600/400	
Capacity	Cooling	H/M/L	KW	5.13	7.03	8.89
			BTU/hr	17,500	24,000	30,300
	Heating	H/M/L	KW	6.68	8.87	11.1
			BTU/hr	22,800	30,300	37900
Water flow rate		gpm	3.5	5	6	
Water pressure drop		kPa	29.3	64	105	
Coil	Tube size	inch	3/8			
	Number of row	-	3			
	Number of tubes for row	-	8			
	Fin Per Inch	FPI	12			
Fan	Type	-	Forward centrifugal			
	Material	-	Galvanized steel			
	Number	-	2	3		
	Number of motor	-	1	2		
Pipe connection	Inlet	inch - mm	3/4 - 25			
	Outlet	inch - mm	3/4 - 25			
	Drain	inch - mm	1/2 - 16			
Drain pan	Type	-	Internal			
	Material	-	Galvanized steel with electrostatic powder coated			
	Insulator	-	Elastomeric			
Filter	Type	-	Washable			
	Material	-	Polypropylene			
Fresh air intake hole		inch - mm	4 - 110			
Sound pressure level	Max	dB(A)	41	44		
Rated current		A	1x 0.55	2x 0.55		
Power supply		PH , V , Hz	1 , 220 , 50			
Dimension	WxHxD	mm	1165x640x233	1415x640x233	1665x640x233	

- Cooling design condition; inlet / outlet water temp: 7 °C (45 °F) / 12 °C (54 °F) and inlet air temp: DB=27 °C (80 °F) , WB=20 °C (67 °F) , sea level: 4000 ft

- Heating design condition; inlet water temp: 60 °C (140 °F) and inlet air temp: 27 °C (80 °F) , sea level: 4000 ft

- Measuring sound pressure level at high speed mode at 2m away and ±2dB tolerance.

- Fan coil pipes connection side can be selected by the customer.

Floor Standing Concealed Model

AFSC020L2- AFSC100L2



Model No.			AFSC020L2	AFSC030L2	AFSC040L2	
Air flow rate	H/M/L	CFM	200/150/100	300/250/150	400/350/200	
Capacity	Cooling	H/M/L	KW	1.8	2.61	3.6
			BTU/hr	6,100	8,900	12,300
	Heating	H/M/L	KW	2.55	3.64	4.74
			BTU/hr	8,700	12,400	16,200
Water flow rate		gpm	1.5	2	2.5	
Water pressure drop		kPa	4.6	8.7	14.5	
Coil	Tube size		inch	3/8		
	Number of row		-	3		
	Number of tubes for row		-	8		
	Fin Per Inch		FPI	12		
Fan	Type		-	Forward centrifugal		
	Material		-	Galvanized steel		
	Number		-	1	2	
	Number of motor		-	1		
Pipe connection	Inlet		inch - mm	¾ - 25		
	Outlet		inch - mm	¾ - 25		
	Drain		inch - mm	½ - 16		
Drain pan	Type		-	Internal		
	Material		-	Galvanized steel with electrostatic powder coated		
	Insulator		-	Elastomeric		
Filter	Type		-	Washable		
	Material		-	Polypropylene		
Fresh air intake hole		inch - mm	4 - 110			
Sound pressure level	Max	dB(A)	41			
Rated current		A	1x 0.55			
Power supply		PH, V, Hz	1, 220, 50			
Dimension	WxHxD	mm	645x520x242	745x520x242	845x520x242	

- Cooling design condition; inlet / outlet water temp: 7 °C (45 °F) / 12 °C (54 °F) and inlet air temp; DB=27 °C (80 °F) , WB=20 °C (67 °F) , sea level: 4000 ft

- Heating design condition; inlet water temp: 60 °C (140 °F) and inlet air temp: 27 °C (80 °F) , sea level: 4000 ft

- Measuring sound pressure level at high speed mode at 2m away and ±2dB tolerance.

- Fan coil pipes connection side can be selected by the customer.

Model No.			AFSC060L2	AFSC080L2	AFSC100L2	
Air flow rate	H/M/L	CFM	600/500/200	800/600/400	1000/600/400	
Capacity	Cooling	H/M/L	KW	5.13	7.03	8.89
			BTU/hr	17,500	24,000	30,300
	Heating	H/M/L	KW	6.68	8.87	11.1
			BTU/hr	22,800	30,300	37900
Water flow rate		gpm	3.5	5	6	
Water pressure drop		kPa	29.3	64	105	
Coil	Tube size	inch	3/8			
	Number of row	-	3			
	Number of tubes for row	-	8			
	Fin Per Inch	FPI	12			
Fan	Type	-	Forward centrifugal			
	Material	-	Galvanized steel			
	Number	-	2	3		
	Number of motor	-	1	2		
Pipe connection	Inlet	inch - mm	3/4 - 25			
	Outlet	inch - mm	3/4 - 25			
	Drain	inch - mm	1/2 - 16			
Drain pan	Type	-	Internal			
	Material	-	Galvanized steel with electrostatic powder coated			
	Insulator	-	Elastomeric			
Filter	Type	-	Washable			
	Material	-	Polypropylene			
Fresh air intake hole		inch - mm	4 - 110			
Sound pressure level	Max	dB(A)	41	44		
Rated current		A	1x 0.55	2x 0.55		
Power supply		PH , V , Hz	1 , 220 , 50			
Dimension	WxHxD	mm	945x520x242	1195x520x242	1445x520x242	

- Cooling design condition; inlet / outlet water temp: 7 °C (45 °F) / 12 °C (54 °F) and inlet air temp; DB=27 °C (80 °F) , WB=20 °C (67 °F) , sea level: 4000 ft

- Heating design condition; inlet water temp: 60 °C (140 °F) and inlet air temp: 27 °C (80 °F) , sea level: 4000 ft

- Measuring sound pressure level at high speed mode at 2m away and ±2dB tolerance.

- Fan coil pipes connection side can be selected by the customer.



Performance Data

Cooling Mode

Water Flow Rate (GPM)	Unit Size-020 Air Flow Rate (CFM)			Water Pressure Drop (kPa)
	200	150	100	
	TC			
2.5	2.13	1.79	1.36	11.48
2	2	1.71	1.32	7.7
1.5	1.8	1.57	1.24	4.6

Heating Mode

Water Flow Rate (GPM)	Unit Size-020 Air Flow Rate (CFM)			Water Pressure Drop (kPa)
	200	150	100	
	Capacity (KW)			
2.5	2.68	2.15	1.56	8.8
2	2.63	2.12	1.54	5.9
1.5	2.55	2.07	1.52	3.61

Water Flow Rate (GPM)	Unit Size-030 Air Flow Rate (CFM)			Water Pressure Drop (kPa)
	300	250	150	
	TC			
2.5	2.82	2.56	1.89	13
2	2.61	2.39	1.8	8.7
1.5	2.29	2.13	1.67	5.2

Water Flow Rate (GPM)	Unit Size-030 Air Flow Rate (CFM)			Water Pressure Drop (kPa)
	300	250	150	
	Capacity (KW)			
2.5	3.73	3.28	2.23	10
2	3.64	3.21	2.2	6.7
1.5	3.48	3.09	2.15	4.1

Water Flow Rate (GPM)	Unit Size-040 Air Flow Rate (CFM)			Water Pressure Drop (kPa)
	400	300	200	
	TC			
3	3.82	3.3	2.59	20
2.5	3.6	3.14	2.5	14.5
2	3.32	2.94	2.38	10

Water Flow Rate (GPM)	Unit Size-040 Air Flow Rate (CFM)			Water Pressure Drop (kPa)
	400	300	200	
	Capacity (KW)			
3	4.85	3.96	2.91	15.8
2.5	4.74	3.89	2.88	11.5
2	4.59	3.8	2.84	7.8

Cooling design condition; inlet / outlet water temp: 7 °C (45 °F) / 12 °C (54 °F) and inlet air temp: 27 °C (80 °F) WB= 20 °C (67 °F) , sea level : 4000 ft

Heating design condition; inlet water temp: 60 °C (140 °F) and inlet air temp: 27 °C (80 °F) , sea level : 4000 ft

TC : Total Cooling Capacity (KW)

Cooling Mode

Water Flow Rate (GPM)	Unit Size-060 Air Flow Rate (CFM)			Water Pressure Drop (kPa)
	600	450	300	
	TC			
4	5.36	4.64	3.68	37
3.5	5.13	4.48	3.58	29.3
3	4.85	4.28	3.47	22.2

Heating Mode

Water Flow Rate (GPM)	Unit Size-060 Air Flow Rate (CFM)			Water Pressure Drop (kPa)
	600	450	300	
	Capacity (KW)			
4	6.79	5.58	4.15	28.8
3.5	6.68	5.51	4.12	23
3	6.54	5.42	4.07	17.4

Water Flow Rate (GPM)	Unit Size-080 Air Flow Rate (CFM)			Water Pressure Drop (kPa)
	800	600	400	
	TC			
5.5	7.22	6.23	4.91	76
5	7.03	6.1	4.83	64
4.5	6.8	5.94	4.74	53

Water Flow Rate (GPM)	Unit Size-080 Air Flow Rate (CFM)			Water Pressure Drop (kPa)
	800	600	400	
	Capacity (KW)			
5.5	8.96	7.36	5.47	59
5	8.87	7.3	5.54	50
4.5	8.75	7.23	5.41	41

Water Flow Rate (GPM)	Unit Size-100 Air Flow Rate (CFM)			Water Pressure Drop (kPa)
	1000	600	450	
	TC			
6.5	9.09	6.9	5.3	122
6	8.89	6.8	5.7	105
5.5	8.65	6.68	5.6	90

Water Flow Rate (GPM)	Unit Size-100 Air Flow Rate (CFM)			Water Pressure Drop (kPa)
	1000	600	450	
	Capacity (KW)			
6.5	11.2	7.84	6.31	95.1
6	11.1	7.8	6.29	83
5.5	10.99	7.75	6.26	71

Cooling design condition; inlet / outlet water temp: 7 °C (45 °F) / 12 °C (54 °F) and inlet air temp: 27 °C (80 °F) WB= 20 °C (67 °F) , sea level : 4000 ft
 Heating design condition; inlet water temp: 60 °C (140 °F) and inlet air temp: 27 °C (80 °F) , sea level : 4000 ft
 TC : Total Cooling Capacity (KW)

ACMHXXXX4

Cooling Mode

Water Flow Rate (GPM)	Unit Size-020 Air Flow Rate (CFM)			Water Pressure Drop (kPa)
	200	150	100	
	TC			
2.5	2.13	1.79	1.36	11.48
2	2	1.71	1.32	7.7
1.5	1.8	1.57	1.24	4.6

Heating Mode

Water Flow Rate (GPM)	Unit Size-020 Air Flow Rate (CFM)			Water Pressure Drop (kPa)
	200	150	100	
	Capacity (KW)			
2.5	1.21	1.01	0.78	3
2	1.18	1	0.77	2.2
1.5	1.15	0.97	0.74	1.8

Water Flow Rate (GPM)	Unit Size-030 Air Flow Rate (CFM)			Water Pressure Drop (kPa)
	300	250	150	
	TC			
2.5	2.82	2.56	1.89	13
2	2.61	2.39	1.8	8.7
1.5	2.29	2.13	1.67	5.2

Water Flow Rate (GPM)	Unit Size-030 Air Flow Rate (CFM)			Water Pressure Drop (kPa)
	300	250	150	
	Capacity (KW)			
2.5	1.65	1.48	1.08	3.5
2	1.62	1.44	1.06	2
1.5	1.56	1.41	1.04	1.5

Water Flow Rate (GPM)	Unit Size-040 Air Flow Rate (CFM)			Water Pressure Drop (kPa)
	400	300	200	
	TC			
3	3.82	3.3	2.59	20
2.5	3.6	3.14	2.5	14.5
2	3.32	2.94	2.38	10

Water Flow Rate (GPM)	Unit Size-040 Air Flow Rate (CFM)			Water Pressure Drop (kPa)
	400	300	200	
	Capacity (KW)			
3	2.12	1.79	1.39	5.4
2.5	2.08	1.76	1.37	4
2	2.03	1.72	1.35	2.8

Cooling design condition; inlet / outlet water temp: 7 °C (44.6 °F) / 12 °C (54 °F) and inlet air temp: 27 °C (80 °F) WB= 20 °C (67 °F) , sea level : 4000 ft

Heating design condition; inlet water temp: 60 °C (140 °F) and inlet air temp: 27 °C (80 °F) , sea level : 4000 ft

TC : Total Cooling Capacity (KW)

Cooling Mode

Water Flow Rate (GPM)	Unit Size-060 Air Flow Rate (CFM)			Water Pressure Drop (kPa)
	600	450	300	
	TC			
4	5.36	4.64	3.68	37
3.5	5.13	4.48	3.58	29.3
3	4.85	4.28	3.47	22.2

Heating Mode

Water Flow Rate (GPM)	Unit Size-060 Air Flow Rate (CFM)			Water Pressure Drop (kPa)
	600	450	300	
	Capacity (KW)			
4	2.9	2.45	1.91	10.1
3.5	2.87	2.43	1.9	8
3	2.82	2.39	1.88	6.1

Water Flow Rate (GPM)	Unit Size-080 Air Flow Rate (CFM)			Water Pressure Drop (kPa)
	800	600	400	
	TC			
5.5	7.22	6.23	4.91	76
5	7.03	6.1	4.83	64
4.5	6.8	5.94	4.74	53

Water Flow Rate (GPM)	Unit Size-080 Air Flow Rate (CFM)			Water Pressure Drop (kPa)
	800	600	400	
	Capacity (KW)			
5.5	3.92	3.31	2.58	22.2
5	3.9	3.29	2.56	19
4.5	3.86	3.26	2.55	16.9

Water Flow Rate (GPM)	Unit Size-100 Air Flow Rate (CFM)			Water Pressure Drop (kPa)
	1000	600	450	
	TC			
6.5	9.09	6.9	5.3	122
6	8.89	6.8	5.7	105
5.5	8.65	6.68	5.6	90

Water Flow Rate (GPM)	Unit Size-100 Air Flow Rate (CFM)			Water Pressure Drop (kPa)
	1000	600	450	
	Capacity (KW)			
6.5	4.92	3.62	3.02	36.1
6	4.89	3.6	3.01	31.3
5.5	4.86	3.58	2.99	27

Cooling design condition; inlet / outlet water temp: 7 °C (44.6 °F) / 12 °C (54 °F) and inlet air temp: 27 °C (80 °F) WB= 20 °C (67 °F) , sea level : 4000 ft

Heating design condition; inlet water temp: 60 °C (140 °F) and inlet air temp: 27 °C (80 °F) , sea level : 4000 ft

TC : Total Cooling Capacity (KW)

Cooling Mode

Heating Mode

Water Flow Rate (GPM)	Unit Size-060 Air Flow Rate (CFM)			Water Pressure Drop (kPa)
	600	450	300	
	TC			
4	5.82	5.41	4.24	11.23
3.5	5.51	5.18	4.11	8.86
3	5.12	4.88	3.94	6.74

Water Flow Rate (GPM)	Unit Size-060 Air Flow Rate (CFM)			Water Pressure Drop (kPa)
	600	450	300	
	Capacity (KW)			
4	8.1	6.57	4.77	8.81
3.5	7.96	6.49	4.74	7
3	7.77	6.37	4.69	5.4

Water Flow Rate (GPM)	Unit Size-080 Air Flow Rate (CFM)			Water Pressure Drop (kPa)
	800	600	400	
	TC			
4.5	6.92	6.52	5.22	13.81
4	6.57	6.25	5.06	11.2
3.5	6.15	5.92	4.87	8.84

Water Flow Rate (GPM)	Unit Size-080 Air Flow Rate (CFM)			Water Pressure Drop (kPa)
	800	600	400	
	Capacity (KW)			
4.5	10.01	8.21	6.06	10.9
4	9.83	8.1	6	8.84
3.5	9.61	7.96	5.94	7

Water Flow Rate (GPM)	Unit Size-100 Air Flow Rate (CFM)			Water Pressure Drop (kPa)
	1000	600	450	
	TC			
6	8.95	7.39	6.19	25.42
5	8.33	7.04	5.97	18.4
4	7.5	6.55	5.64	12.38

Water Flow Rate (GPM)	Unit Size-100 Air Flow Rate (CFM)			Water Pressure Drop (kPa)
	1000	600	450	
	Capacity (KW)			
6	12.49	8.67	6.93	19.95
5	12.18	8.54	6.85	14.51
4	11.71	8.34	6.74	9.84

Water Flow Rate (GPM)	Unit Size-120 Air Flow Rate (CFM)			Water Pressure Drop (kPa)
	1200	800	650	
	TC			
7	10.23	9.01	8.02	33.37
6	9.65	8.63	7.73	25.4
5	8.91	8.12	7.35	18.36

Water Flow Rate (GPM)	Unit Size-120 Air Flow Rate (CFM)			Water Pressure Drop (kPa)
	1200	800	650	
	Capacity (KW)			
7	14.38	10.87	9.32	26.16
6	14.07	10.71	9.21	20
5	13.65	10.48	9.06	14.55

Cooling design condition; inlet / outlet water temp: 7 °C (44.6 °F) / 12 °C (54 °F) and inlet air temp: 27 °C (80 °F) WB= 20 °C (67 °F) , sea level : 4000 ft

Heating design condition; inlet water temp: 60 °C (140 °F) and inlet air temp: 27 °C (80 °F) , sea level : 4000 ft

TC : Total Cooling Capacity (KW)

ACHAXXX2

Cooling Mode

Water Flow Rate (GPM)	Unit Size-140 Air Flow Rate (CFM)			Water Pressure Drop (kPa)
	1400	1000	800	
	TC			
8	12.67	10.93	9.62	52.52
7	12.06	10.53	9.34	41.43
6	11.31	10.02	8.96	31.51

Heating Mode

Water Flow Rate (GPM)	Unit Size-140 Air Flow Rate (CFM)			Water Pressure Drop (kPa)
	1400	1000	800	
	Capacity (KW)			
8	17.36	13.73	11.63	41.22
7	17.05	13.56	11.51	32.65
6	17.36	13.73	11.63	41.22

Water Flow Rate (GPM)	Unit Size-160 Air Flow Rate (CFM)			Water Pressure Drop (kPa)
	1600	1200	1000	
	TC			
10	14.47	12.75	11.51	77.94
9	13.99	12.41	11.25	64.65
8	13.41	12	10.93	52.45

Water Flow Rate (GPM)	Unit Size-160 Air Flow Rate (CFM)			Water Pressure Drop (kPa)
	1600	1200	1000	
	Capacity (KW)			
10	19.5	15.98	13.98	61
9	19.26	15.82	13.87	50.7
8	18.95	15.64	13.73	41.3

Water Flow Rate (GPM)	Unit Size-180 Air Flow Rate (CFM)			Water Pressure Drop (kPa)
	1800	1400	1200	
	TC			
10	16.42	14.78	13.6	93
9	15.82	14.34	13.25	77.14
8	15.11	13.81	12.81	62.58

Water Flow Rate (GPM)	Unit Size-180 Air Flow Rate (CFM)			Water Pressure Drop (kPa)
	1800	1400	1200	
	Capacity (KW)			
10	22.25	18.71	16.73	73.07
9	21.95	18.51	16.58	60.8
8	21.57	18.26	16.39	49.52

Water Flow Rate (GPM)	Unit Size-200 Air Flow Rate (CFM)			Water Pressure Drop (kPa)
	2000	1600	1400	
	TC			
12	18.26	16.62	15.42	128
11	17.77	16.24	15.15	110
10	17.19	15.8	14.78	92.91

Water Flow Rate (GPM)	Unit Size-200 Air Flow Rate (CFM)			Water Pressure Drop (kPa)
	2000	1600	1400	
	Capacity (KW)			
12	24.4	20.93	19.01	100.56
11	24.15	20.76	18.88	86.4
10	23.85	20.55	18.71	73.16

Cooling design condition; inlet / outlet water temp: 7 °C (44.6 °F) / 12 °C (54 °F) and inlet air temp: 27 °C (80 °F) WB= 20 °C (67 °F) , sea level : 4000 ft
 Heating design condition; inlet water temp: 60 °C (140 °F) and inlet air temp: 27 °C (80 °F) , sea level : 4000 ft
 TC : Total Cooling Capacity (KW)

Cooling Mode

Water Flow Rate (GPM)	Unit Size-060 Air Flow Rate (CFM)			Water Pressure Drop (kPa)
	600	450	300	
	TC			
4	5.82	5.41	4.24	11.23
3.5	5.51	5.18	4.11	8.86
3	5.12	4.88	3.94	6.74

Heating Mode

Water Flow Rate (GPM)	Unit Size-060 Air Flow Rate (CFM)			Water Pressure Drop (kPa)
	600	450	300	
	Capacity (KW)			
4	5.5	4.58	3.47	4.1
3.5	5.41	4.52	3.44	3.21
3	5.28	4.43	3.39	2.45

Water Flow Rate (GPM)	Unit Size-080 Air Flow Rate (CFM)			Water Pressure Drop (kPa)
	800	600	400	
	TC			
4.5	6.92	6.52	5.22	13.81
4	6.57	6.25	5.06	11.2
3.5	6.15	5.92	4.87	8.84

Water Flow Rate (GPM)	Unit Size-080 Air Flow Rate (CFM)			Water Pressure Drop (kPa)
	800	600	400	
	Capacity (KW)			
4.5	6.65	5.58	4.28	5
4	6.54	5.5	4.24	4.1
3.5	6.4	5.41	4.18	3.22

Water Flow Rate (GPM)	Unit Size-100 Air Flow Rate (CFM)			Water Pressure Drop (kPa)
	1000	600	450	
	TC			
6	8.95	7.39	6.19	25.42
5	8.33	7.04	5.97	18.4
4	7.5	6.55	5.64	12.38

Water Flow Rate (GPM)	Unit Size-100 Air Flow Rate (CFM)			Water Pressure Drop (kPa)
	1000	600	450	
	Capacity (KW)			
6	8.27	6	4.93	9.21
5	8.07	5.9	4.86	6.7
4	7.78	5.75	4.77	4.54

Water Flow Rate (GPM)	Unit Size-120 Air Flow Rate (CFM)			Water Pressure Drop (kPa)
	1200	800	650	
	TC			
7	10.23	9.01	8.02	33.37
6	9.65	8.63	7.73	25.4
5	8.91	8.12	7.35	18.36

Water Flow Rate (GPM)	Unit Size-120 Air Flow Rate (CFM)			Water Pressure Drop (kPa)
	1200	800	650	
	Capacity (KW)			
7	9.39	7.32	6.39	12.1
6	9.2	7.21	6.31	9.23
5	8.95	7.06	6.2	6.71

Cooling design condition; inlet / outlet water temp: 7 °C (44.6 °F) / 12 °C (54 °F) and inlet air temp: 27 °C (80 °F) WB= 20 °C (67 °F) , sea level : 4000 ft

Heating design condition; inlet water temp: 60 °C (140 °F) and inlet air temp: 27 °C (80 °F) , sea level : 4000 ft

TC : Total Cooling Capacity (KW)

ACHAXXXX4

Cooling Mode

Water Flow Rate (GPM)	Unit Size-140 Air Flow Rate (CFM)			Water Pressure Drop (kPa)
	1400	1000	800	
	TC			
8	12.67	10.93	9.62	52.52
7	12.06	10.53	9.34	41.43
6	11.31	10.02	8.96	31.51

Heating Mode

Water Flow Rate (GPM)	Unit Size-140 Air Flow Rate (CFM)			Water Pressure Drop (kPa)
	1400	1000	800	
	Capacity (KW)			
8	11.49	9.32	8.05	19.19
7	11.31	9.2	7.97	15.15
6	11.06	9.05	7.85	11.6

Water Flow Rate (GPM)	Unit Size-160 Air Flow Rate (CFM)			Water Pressure Drop (kPa)
	1600	1200	1000	
	TC			
10	14.47	12.75	11.51	77.94
9	13.99	12.41	11.25	64.65
8	13.41	12	10.93	52.45

Water Flow Rate (GPM)	Unit Size-160 Air Flow Rate (CFM)			Water Pressure Drop (kPa)
	1600	1200	1000	
	Capacity (KW)			
10	12.77	10.68	9.49	28.35
9	12.62	10.58	9.42	23.6
8	12.44	10.46	9.32	19.2

Water Flow Rate (GPM)	Unit Size-180 Air Flow Rate (CFM)			Water Pressure Drop (kPa)
	1800	1400	1200	
	TC			
10	16.42	14.78	13.6	93
9	15.82	14.34	13.25	77.14
8	15.11	13.81	12.81	62.58

Water Flow Rate (GPM)	Unit Size-180 Air Flow Rate (CFM)			Water Pressure Drop (kPa)
	1800	1400	1200	
	Capacity (KW)			
10	14.73	12.61	11.42	34.16
9	14.55	12.48	11.32	28.42
8	14.33	12.32	11.19	23.14

Water Flow Rate (GPM)	Unit Size-200 Air Flow Rate (CFM)			Water Pressure Drop (kPa)
	2000	1600	1400	
	TC			
12	18.26	16.62	15.42	128
11	17.77	16.24	15.15	110
10	17.19	15.8	14.78	92.91

Water Flow Rate (GPM)	Unit Size-200 Air Flow Rate (CFM)			Water Pressure Drop (kPa)
	2000	1600	1400	
	Capacity (KW)			
12	16	13.95	12.81	47.1
11	15.86	13.84	12.72	40.4
10	15.69	13.71	12.61	34.2

Cooling design condition; inlet / outlet water temp: 7 °C (44.6 °F) / 12 °C (54 °F) and inlet air temp: 27 °C (80 °F) WB= 20 °C (67 °F) , sea level : 4000 ft

Heating design condition; inlet water temp: 60 °C (140 °F) and inlet air temp: 27 °C (80 °F) , sea level : 4000 ft

TC : Total Cooling Capacity (KW)

Cooling Mode

Unit Size (at High Speed)	Water Flow Rate (GPM)	Saturated Temperature Leaving Evaporator °F (°C)					
		41 (5)		45 (7)		50 (10)	
		Capacity (KW)					
		TC	SHC	TC	SHC	TC	SHC
020	2.5	1.85	1.41	1.57	1.28	1.12	1.08
	2	1.75	1.35	1.48	1.22	1.06	1.06
	1.5	1.58	1.25	1.34	1.13	1	1
030	2.5	2.47	1.93	2.09	1.75	1.5	1.5
	2	2.3	1.83	1.95	1.66	1.45	1.45
	1.5	2.04	1.66	1.73	1.51	1.37	1.37
040	3	3.2	2.52	2.71	2.28	1.94	1.94
	2.5	3.02	2.41	2.56	2.18	1.89	1.89
	2	2.78	2.25	2.35	2.04	1.82	1.82
060	4	4.46	3.56	3.77	3.23	2.74	2.74
	3.5	4.28	3.45	3.62	3.13	2.69	2.69
	3	4.07	3.31	3.43	3	2.62	2.62
080	5.5	6.17	4.89	5.22	4.43	3.72	3.72
	5	6.02	4.8	5.09	4.35	3.67	3.67
	4.5	5.85	4.68	4.93	4.25	3.62	3.62
100	6.5	7.76	6.14	6.55	5.56	4.66	4.66
	6	7.6	6.04	6.41	5.47	4.61	4.61
	5.5	7.42	5.92	6.26	5.37	4.56	4.56

Heating Mode

Unit Size (at High Speed)	Water Flow Rate (GPM)	Intering Water °F (°C)		
		140 (60)	149 (65)	158 (70)
		Capacity (KW)		
		TC	SHC	TC
020	2.5	3.19	3.59	3.99
	2	3.13	3.53	3.92
	1.5	3.04	3.42	3.81
030	2.5	4.46	5.02	5.59
	2	4.35	4.9	5.45
	1.5	4.17	4.7	5.23
040	3	5.77	6.49	7.22
	2.5	5.65	6.36	7.08
	2	5.47	6.17	6.86
060	4	8.09	9.11	10.13
	3.5	7.96	8.97	9.98
	3	7.8	8.79	9.77
080	5.5	10.91	12.29	13.66
	5	10.8	12.16	13.52
	4.5	10.67	12.02	13.36
100	6.5	13.64	15.35	17.06
	6	13.52	15.22	16.92
	5.5	13.39	15.07	16.75

Cooling design condition; inlet air temp: 24 °C (75 °F) WB= 17 °C (62 °F) , sea level : 4000 ft

Heating design condition; inlet air temp: 20 °C (68 °F) , sea level : 4000 ft

TC : Total Cooling Capacity SHC : Sensible Capacity

Cooling Mode

Heating Mode

Unit Size (at High Speed)	Water Flow Rate (GPM)	Saturated Temperature Leaving Evaporator °F (°C)					
		41 (5)		45 (7)		50 (10)	
		Capacity (KW)					
		TC	SHC	TC	SHC	TC	SHC
020	2.5	2.4	1.56	2.13	1.43	1.66	1.23
	2	2.26	1.48	2	1.36	1.57	1.17
	1.5	2.05	1.36	1.8	1.26	1.42	1.08
030	2.5	3.2	2.12	2.82	1.95	2.21	1.68
	2	2.98	1.99	2.61	1.83	2.05	1.58
	1.5	2.64	1.8	2.29	1.66	1.81	1.43
040	3	4.14	2.75	3.82	2.49	2.85	2.18
	2.5	3.91	2.62	3.6	2.37	2.68	2.07
	2	3.59	2.44	3.32	2.2	2.45	1.93
060	4	5.76	3.88	5.36	3.49	3.95	3.07
	3.5	5.54	3.75	5.13	3.37	3.79	2.96
	3	5.25	3.58	4.85	3.22	3.58	2.83
080	5.5	7.99	5.34	7.22	4.86	5.48	4.22
	5	7.79	5.23	7.03	4.75	5.33	4.13
	4.5	7.55	5.1	6.8	4.63	5.16	4.02
100	6.5	10.03	6.7	9.09	6.08	6.87	5.29
	6	9.82	6.59	8.89	5.95	6.72	5.19
	5.5	9.59	6.45	8.65	5.84	6.54	5.08

Unit Size (at High Speed)	Water Flow Rate (GPM)	Intering Water °F (°C)		
		140 (60)	149 (65)	158 (70)
		Capacity (KW)		
020	2.5	2.86	3.26	3.66
	2	2.81	3.2	3.6
	1.5	2.73	3.11	3.49
030	2.5	4	4.56	5.12
	2	3.91	4.45	5
	1.5	3.75	4.28	4.8
040	3	5.18	5.9	6.63
	2.5	5.07	5.78	6.49
	2	4.92	5.61	6.3
060	4	7.27	8.29	9.3
	3.5	7.16	8.16	9.16
	3	7.01	7.99	8.97
080	5.5	9.8	11.17	12.54
	5	9.71	11.06	12.41
	4.5	9.59	10.93	12.27
100	6.5	12.25	13.96	15.66
	6	12.15	13.84	15.53
	5.5	12.03	13.7	15.38

Cooling design condition; inlet air temp: 27 °C (80 °F) WB= 19 °C (67 °F), sea level : 4000 ft

Heating design condition; inlet air temp: 24 °C (75 °F), sea level : 4000 ft

TC : Total Cooling Capacity SHC : Sensible Capacity

Cooling Mode

Unit Size (at High Speed)	Water Flow Rate (GPM)	Saturated Temperature Leaving Evaporator °F (°C)					
		41 (5)		45 (7)		50 (10)	
		Capacity (KW)					
		TC	SHC	TC	SHC	TC	SHC
020	2.5	3	1.7	2.72	1.57	2.26	1.38
	2	2.83	1.61	2.56	1.49	2.13	1.31
	1.5	2.56	1.47	2.31	1.37	1.92	1.2
030	2.5	4	2.29	3.61	2.12	2.99	1.86
	2	3.72	2.15	3.35	1.99	2.77	1.74
	1.5	3.29	1.93	2.96	1.79	2.44	1.57
040	3	5.17	2.97	4.66	2.75	3.86	2.41
	2.5	4.88	2.83	4.39	2.61	3.63	2.29
	2	4.48	2.62	4.02	2.42	3.31	2.12
060	4	7.2	4.18	6.48	3.86	5.35	3.38
	3.5	6.91	4.03	6.21	3.72	5.12	3.26
	3	6.54	3.84	5.88	3.55	4.83	3.1
080	5.5	9.98	5.76	8.98	5.33	7.41	4.66
	5	9.72	5.63	8.75	5.2	7.21	4.56
	4.5	9.42	5.48	8.47	5.06	6.97	4.43
100	6.5	12.53	7.23	11.27	6.68	9.3	5.85
	6	12.26	7.1	11.02	6.55	9.08	5.73
	5.5	11.95	6.94	10.74	6.41	8.84	5.6

Heating Mode

Unit Size (at High Speed)	Water Flow Rate (GPM)	Intering Water °F (°C)		
		140 (60)	149 (65)	158 (70)
		Capacity (KW)		
020	2.5	2.68	3.02	3.42
	2	2.63	2.97	3.36
	1.5	2.55	2.89	3.27
030	2.5	3.73	4.24	4.8
	2	3.64	4.14	4.68
	1.5	3.48	3.97	4.5
040	3	4.85	5.48	6.2
	2.5	4.74	5.37	6.08
	2	4.59	5.21	5.9
060	4	6.79	7.7	8.71
	3.5	6.68	7.58	8.58
	3	6.54	7.43	8.41
080	5.5	8.96	10.38	11.74
	5	8.87	10.28	11.63
	4.5	8.75	10.16	11.5
100	6.5	11.2	12.97	14.67
	6	11.1	12.86	14.55
	5.5	10.99	12.74	14.41

Cooling design condition; inlet air temp: 29 °C (85 °F) WB= 22 °C (72 °F), sea level : 4000 ft

Heating design condition; inlet air temp: 27 °C (80 °F), sea level : 4000 ft

TC : Total Cooling Capacity SHC : Sensible Capacity

Cooling Mode

Unit Size (at High Speed)	Water Flow Rate (GPM)	Saturated Temperature Leaving Evaporator °F (°C)					
		41 (5)		45 (7)		50 (10)	
		Capacity (KW)					
		TC	SHC	TC	SHC	TC	SHC
020	2.5	1.85	1.41	1.57	1.28	1.12	1.08
	2	1.75	1.35	1.48	1.22	1.06	1.06
	1.5	1.58	1.25	1.34	1.13	1	1
030	2.5	2.47	1.93	2.09	1.75	1.5	1.5
	2	2.3	1.83	1.95	1.66	1.45	1.45
	1.5	2.04	1.66	1.73	1.51	1.37	1.37
040	3	3.2	2.52	2.71	2.28	1.94	1.94
	2.5	3.02	2.41	2.56	2.18	1.89	1.89
	2	2.78	2.25	2.35	2.04	1.82	1.82
060	4	4.46	3.56	3.77	3.23	2.74	2.74
	3.5	4.28	3.45	3.62	3.13	2.69	2.69
	3	4.07	3.31	3.43	3	2.62	2.62
080	5.5	6.17	4.89	5.22	4.43	3.72	3.72
	5	6.02	4.8	5.09	4.35	3.67	3.67
	4.5	5.85	4.68	4.93	4.25	3.62	3.62
100	6.5	7.76	6.14	6.55	5.56	4.66	4.66
	6	7.6	6.04	6.41	5.47	4.61	4.61
	5.5	7.42	5.92	6.26	5.37	4.56	4.56

Heating Mode

Unit Size (at High Speed)	Water Flow Rate (GPM)	Entering Water °F (°C)		
		140 (60)	149 (65)	158 (70)
		Capacity (KW)		
		TC	SHC	TC
020	2.5	1.45	1.64	1.82
	2	1.43	1.61	1.79
	1.5	1.38	1.56	1.74
030	2.5	1.99	2.25	2.5
	2	1.95	2.2	2.45
	1.5	1.88	2.12	2.36
040	3	2.55	2.88	3.2
	2.5	2.51	2.83	3.15
	2	2.44	2.75	3.07
060	4	3.49	3.94	4.38
	3.5	3.45	3.89	4.33
	3	3.39	3.83	4.26
080	5.5	4.72	5.32	5.92
	5	4.69	5.28	5.88
	4.5	4.65	5.23	5.82
100	6.5	5.93	6.67	7.42
	6	5.89	6.63	7.38
	5.5	5.85	6.59	7.33

Cooling design condition; inlet air temp: 24 °C (75 °F) WB= 17 °C (62 °F), sea level : 4000 ft

Heating design condition; inlet air temp: 20 °C (68 °F), sea level : 4000 ft

TC : Total Cooling Capacity SHC : Sensible Capacity

Cooling Mode

Unit Size (at High Speed)	Water Flow Rate (GPM)	Saturated Temperature Leaving Evaporator °F (°C)					
		41 (5)		45 (7)		50 (10)	
		Capacity (KW)					
		TC	SHC	TC	SHC	TC	SHC
020	2.5	2.4	1.56	2.13	1.43	1.66	1.23
	2	2.26	1.48	2	1.36	1.57	1.17
	1.5	2.05	1.36	1.8	1.26	1.42	1.08
030	2.5	3.2	2.12	2.82	1.95	2.21	1.68
	2	2.98	1.99	2.61	1.83	2.05	1.58
	1.5	2.64	1.8	2.29	1.66	1.81	1.43
040	3	4.14	2.75	3.82	2.49	2.85	2.18
	2.5	3.91	2.62	3.6	2.37	2.68	2.07
	2	3.59	2.44	3.32	2.2	2.45	1.93
060	4	5.76	3.88	5.36	3.49	3.95	3.07
	3.5	5.54	3.75	5.13	3.37	3.79	2.96
	3	5.25	3.58	4.85	3.22	3.58	2.83
080	5.5	7.99	5.34	7.22	4.86	5.48	4.22
	5	7.79	5.23	7.03	4.75	5.33	4.13
	4.5	7.55	5.1	6.8	4.63	5.16	4.02
100	6.5	10.03	6.7	9.09	6.08	6.87	5.29
	6	9.82	6.59	8.89	5.95	6.72	5.19
	5.5	9.59	6.45	8.65	5.84	6.54	5.08

Heating Mode

Unit Size (at High Speed)	Water Flow Rate (GPM)	Intering Water °F (°C)		
		140 (60)	149 (65)	158 (70)
		Capacity (KW)		
		TC	SHC	TC
020	2.5	1.31	1.49	1.68
	2	1.28	1.46	1.65
	1.5	1.25	1.42	1.6
030	2.5	1.79	2.05	2.3
	2	1.75	2	2.25
	1.5	1.69	1.93	2.17
040	3	2.3	2.62	2.95
	2.5	2.26	2.58	2.9
	2	2.2	2.51	2.82
060	4	3.15	3.59	4.03
	3.5	3.11	3.55	3.98
	3	3.06	3.49	3.92
080	5.5	4.26	4.85	5.45
	5	4.23	4.82	5.41
	4.5	4.19	4.77	5.36
100	6.5	5.34	6.09	6.83
	6	5.31	6.05	6.79
	5.5	5.27	6.01	6.74

Cooling design condition; inlet air temp: 27 °C (80 °F) WB= 19 °C (67 °F), sea level : 4000 ft

Heating design condition; inlet air temp: 24 °C (75 °F), sea level : 4000 ft

TC : Total Cooling Capacity

SHC : Sensible Capacity

Cooling Mode

Heating Mode

Unit Size (at High Speed)	Water Flow Rate (GPM)	Saturated Temperature Leaving Evaporator °F (°C)					
		41 (5)		45 (7)		50 (10)	
		Capacity (KW)					
		TC	SHC	TC	SHC	TC	SHC
020	2.5	3	1.7	2.72	1.57	2.26	1.38
	2	2.83	1.61	2.56	1.49	2.13	1.31
	1.5	2.56	1.47	2.31	1.37	1.92	1.2
030	2.5	4	2.29	3.61	2.12	2.99	1.86
	2	3.72	2.15	3.35	1.99	2.77	1.74
	1.5	3.29	1.93	2.96	1.79	2.44	1.57
040	3	5.17	2.97	4.66	2.75	3.86	2.41
	2.5	4.88	2.83	4.39	2.61	3.63	2.29
	2	4.48	2.62	4.02	2.42	3.31	2.12
060	4	7.2	4.18	6.48	3.86	5.35	3.38
	3.5	6.91	4.03	6.21	3.72	5.12	3.26
	3	6.54	3.84	5.88	3.55	4.83	3.1
080	5.5	9.98	5.76	8.98	5.33	7.41	4.66
	5	9.72	5.63	8.75	5.2	7.21	4.56
	4.5	9.42	5.48	8.47	5.06	6.97	4.43
100	6.5	12.53	7.23	11.27	6.68	9.3	5.85
	6	12.26	7.1	11.02	6.55	9.08	5.73
	5.5	11.95	6.94	10.74	6.41	8.84	5.6

Unit Size (at High Speed)	Water Flow Rate (GPM)	Intering Water °F (°C)		
		140 (60)	149 (65)	158 (70)
		Capacity (KW)		
020	2.5	1.21	1.39	1.57
	2	1.18	1.36	1.54
	1.5	1.15	1.32	1.5
030	2.5	1.65	1.91	2.16
	2	1.62	1.86	2.11
	1.5	1.56	1.8	2.04
040	3	2.12	2.44	2.76
	2.5	2.08	2.4	2.72
	2	2.03	2.34	2.65
060	4	2.9	3.34	3.78
	3.5	2.87	3.3	3.74
	3	2.82	3.25	3.68
080	5.5	3.92	4.52	5.11
	5	3.9	4.49	5.08
	4.5	3.86	4.45	5.03
100	6.5	4.92	5.67	6.41
	6	4.89	5.63	6.37
	5.5	4.86	5.59	6.33

Cooling design condition; inlet air temp: 29 °C (85 °F) WB= 22 °C (72 °F), sea level : 4000 ft

Heating design condition; inlet air temp: 27 °C (80 °F), sea level : 4000 ft

TC : Total Cooling Capacity SHC : Sensible Capacity

Cooling Mode

Heating Mode

Unit Size (at High Speed)	Water Flow Rate (GPM)	Saturated Temperature Leaving Evaporator °F (°C)					
		41 (5)		45 (7)		50 (10)	
		Capacity (KW)					
		TC	SHC	TC	SHC	TC	SHC
060	4	5.22	4.03	4.41	3.65	3.27	3.27
	3.5	4.95	3.87	4.18	3.5	3.19	3.19
	3	4.62	3.66	3.9	3.32	3.09	3.09
080	4.5	6.22	4.92	5.25	4.46	4.02	4.02
	4	5.93	4.73	5	4.29	3.93	3.93
	3.5	5.57	4.5	4.69	4.08	3.81	3.81
100	6	8.03	6.31	6.77	5.71	5.06	5.06
	5	7.5	5.98	6.32	5.41	4.91	4.91
	4	6.79	5.52	5.72	5	4.68	4.68
120	7	9.19	7.29	7.75	6.6	5.83	5.83
	6	8.7	6.98	7.33	6.32	5.68	5.68
	5	8.06	6.57	6.78	5.95	5.48	5.48
140	8	11.35	8.9	9.57	8.05	7.09	7.09
	7	10.84	8.58	9.13	7.76	6.94	6.94
	6	10.21	8.18	8.58	7.4	6.75	6.75
160	10	12.94	10.15	10.92	9.18	7.98	7.98
	9	12.54	9.9	10.57	8.96	7.87	7.87
	8	12.05	9.59	10.15	8.68	7.72	7.72
180	10	14.7	11.51	12.39	10.4	9.13	9.13
	9	14.2	11.2	11.95	10.12	8.99	8.99
	8	13.61	10.82	11.44	9.78	8.81	8.81
200	12	16.32	12.78	13.76	11.55	10.02	10.02
	11	15.91	12.52	13.4	11.32	9.91	9.91
	10	15.43	12.22	12.99	11.05	9.77	9.77

Unit Size (at High Speed)	Water Flow Rate (GPM)	Intering Water °F (°C)		
		140 (60)	149 (65)	158 (70)
		Capacity (KW)		
		TC	SHC	TC
060	4	9.76	11	12.23
	3.5	9.59	10.8	12.02
	3	9.36	10.55	11.7
080	4.5	12.05	13.58	15.11
	4	11.83	13.34	14.84
	3.5	11.56	13.03	14.5
100	6	15.04	16.94	18.85
	5	14.66	16.51	18.37
	4	14.1	15.9	17.67
120	7	17.31	19.5	21.7
	6	16.94	19.08	21.23
	5	16.42	18.51	20.59
140	8	20.91	23.55	26.19
	7	20.53	23.13	25.72
	6	20.04	22.57	25.1
160	10	23.5	26.45	29.41
	9	23.19	26.11	29.04
	8	22.82	25.7	28.58
180	10	26.8	30.17	33.55
	9	26.43	29.75	33.08
	8	25.97	29.24	32.51
200	12	29.39	33.08	36.78
	11	29.08	32.74	36.4
	10	28.72	32.33	35.95

Cooling design condition; inlet air temp: 24 °C (75 °F) WB= 17 °C (62 °F) , sea level : 4000 ft

Heating design condition; inlet air temp: 20 °C (68 °F) , sea level : 4000 ft

TC : Total Cooling Capacity

SHC : Sensible Capacity

Cooling Mode

Heating Mode

Unit Size (at High Speed)	Water Flow Rate (GPM)	Saturated Temperature Leaving Evaporator °F (°C)					
		41 (5)		45 (7)		50 (10)	
		Capacity (KW)					
		TC	SHC	TC	SHC	TC	SHC
060	4	6.63	4.36	5.82	3.99	4.55	3.43
	3.5	6.28	4.17	5.51	3.82	4.3	3.28
	3	5.84	3.92	5.12	3.59	3.99	3.09
080	4.5	7.89	5.29	6.92	4.84	5.39	4.16
	4	7.5	5.06	6.57	4.64	5.11	3.99
	3.5	7.03	4.79	6.15	4.39	4.78	3.78
100	6	10.21	6.8	8.95	6.22	6.97	5.35
	5	9.51	6.41	8.33	5.87	6.47	5.04
	4	8.57	5.87	7.5	5.38	5.81	4.62
120	7	11.67	7.84	10.23	7.18	7.96	6.17
	6	11.02	7.47	9.65	6.84	7.5	5.88
	5	10.18	6.99	8.91	6.4	6.91	5.5
140	8	14.46	9.62	12.67	8.79	9.85	7.55
	7	13.78	9.24	12.06	8.45	9.36	7.25
	6	12.94	8.76	11.31	8.01	8.76	6.87
160	10	16.51	10.98	14.47	10.05	11.27	8.63
	9	15.97	10.68	13.99	9.77	10.88	8.39
	8	15.32	10.31	13.41	9.43	10.41	8.1
180	10	18.75	12.46	16.42	11.39	12.77	9.76
	9	18.09	12.08	15.82	11.04	12.28	9.47
	8	17.29	11.64	15.11	10.63	11.71	9.11
200	12	20.84	13.84	18.26	12.66	14.21	10.86
	11	20.29	13.53	17.77	12.37	13.81	10.62
	10	19.65	13.17	17.19	12.04	13.34	10.33

Unit Size (at High Speed)	Water Flow Rate (GPM)	Intering Water °F (°C)		
		140 (60)	149 (65)	158 (70)
		Capacity (KW)		
060	4	8.8	10.03	11.27
	3.5	8.65	9.86	11.07
	3	8.44	9.63	10.82
080	4.5	10.87	12.4	13.92
	4	10.68	12.18	13.68
	3.5	10.43	11.9	13.37
100	6	13.57	15.47	17.37
	5	13.22	15.07	16.93
	4	12.71	14.5	16.29
120	7	15.62	17.8	19.99
	6	15.28	17.42	19.56
	5	14.81	16.89	18.98
140	8	18.86	21.49	24.13
	7	18.52	21.11	23.7
	6	18.07	20.6	23.13
160	10	21.19	24.14	27.09
	9	20.92	23.83	26.76
	8	20.58	23.46	26.34
180	10	24.17	27.54	30.91
	9	23.83	27.16	30.48
	8	23.42	26.69	29.96
200	12	26.5	30.19	33.89
	11	26.23	29.88	33.54
	10	25.9	29.51	33.12

Cooling design condition; inlet air temp: 27 °C (80 °F) WB= 19 °C (67 °F), sea level : 4000 ft

Heating design condition; inlet air temp: 24 °C (75 °F), sea level : 4000 ft

TC : Total Cooling Capacity

SHC : Sensible Capacity

ACHAXXX2

Cooling Mode

Heating Mode

Unit Size (at High Speed)	Water Flow Rate (GPM)	Saturated Temperature Leaving Evaporator °F (°C)					
		41 (5)		45 (7)		50 (10)	
		Capacity (KW)					
		TC	SHC	TC	SHC	TC	SHC
060	4	8.28	4.72	7.45	4.36	6.15	3.81
	3.5	7.83	4.5	7.04	4.15	5.8	3.63
	3	7.27	4.22	6.54	3.89	5.38	3.4
080	4.5	9.83	5.69	8.83	5.25	7.27	4.59
	4	9.33	5.43	8.38	5.02	6.89	4.38
	3.5	8.74	5.13	7.84	4.74	6.44	4.14
100	6	12.72	7.33	11.43	6.76	9.41	5.91
	5	11.83	6.88	10.62	6.35	8.72	5.54
	4	10.65	6.26	9.54	5.78	7.81	5.04
120	7	14.55	8.43	13.07	7.78	10.75	6.8
	6	13.71	8	12.31	7.39	10.1	6.45
	5	12.65	7.45	11.34	6.88	9.29	6
140	8	18.01	10.36	16.18	9.56	13.3	8.33
	7	17.15	9.93	15.39	9.15	12.62	7.97
	6	16.07	9.38	14.4	8.64	11.78	7.52
160	10	20.58	11.84	18.5	10.93	15.23	9.54
	9	19.89	11.49	17.86	10.6	14.68	9.25
	8	19.07	11.07	17.1	10.21	14.03	8.9
180	10	23.37	13.43	20.97	12.37	17.23	10.78
	9	22.51	13	20.18	11.97	16.55	10.42
	8	21.49	12.48	19.25	11.49	15.75	10
200	12	25.98	14.93	23.34	13.77	19.2	12.01
	11	25.28	14.58	22.68	13.43	18.64	11.71
	10	24.45	14.16	21.93	13.05	17.99	11.37

Unit Size (at High Speed)	Water Flow Rate (GPM)	Intering Water °F (°C)		
		140 (60)	149 (65)	158 (70)
		Capacity (KW)		
060	4	8.1	9.33	10.56
	3.5	7.96	9.17	10.38
	3	7.77	8.95	10.14
080	4.5	10.01	11.53	13.05
	4	9.83	11.32	12.82
	3.5	9.6	11.07	12.53
100	6	12.49	14.38	16.28
	5	12.17	14.02	15.87
	4	11.71	13.49	15.27
120	7	14.38	16.56	18.74
	6	14.07	16.2	18.34
	5	13.65	15.72	17.79
140	8	17.36	19.99	22.61
	7	17.05	19.63	22.21
	6	16.64	19.16	21.69
160	10	19.5	22.45	25.4
	9	19.26	22.17	25.08
	8	18.95	21.82	24.69
180	10	22.25	25.61	28.97
	9	21.95	25.26	28.57
	8	21.57	24.82	28.08
200	12	24.4	28.08	31.76
	11	24.15	27.79	31.44
	10	23.85	27.45	31.05

Cooling design condition; inlet air temp: 29 °C (85 °F) WB= 22 °C (72 °F) , sea level : 4000 ft
 Heating design condition; inlet air temp: 27 °C (80 °F) , sea level : 4000 ft
 TC : Total Cooling Capacity SHC : Sensible Capacity

Cooling Mode

Heating Mode

Unit Size (at High Speed)	Water Flow Rate (GPM)	Saturated Temperature Leaving Evaporator °F (°C)					
		41 (5)		45 (7)		50 (10)	
		Capacity (KW)					
		TC	SHC	TC	SHC	TC	SHC
060	4	5.22	4.03	4.41	3.65	3.27	3.27
	3.5	4.95	3.87	4.18	3.5	3.19	3.19
	3	4.62	3.66	3.9	3.32	3.09	3.09
080	4.5	6.22	4.92	5.25	4.46	4.02	4.02
	4	5.93	4.73	5	4.29	3.93	3.93
	3.5	5.57	4.5	4.69	4.08	3.81	3.81
100	6	8.03	6.31	6.77	5.71	5.06	5.06
	5	7.5	5.98	6.32	5.41	4.91	4.91
	4	6.79	5.52	5.72	5	4.68	4.68
120	7	9.19	7.29	7.75	6.6	5.83	5.83
	6	8.7	6.98	7.33	6.32	5.68	5.68
	5	8.06	6.57	6.78	5.95	5.48	5.48
140	8	11.35	8.9	9.57	8.05	7.09	7.09
	7	10.84	8.58	9.13	7.76	6.94	6.94
	6	10.21	8.18	8.58	7.4	6.75	6.75
160	10	12.94	10.15	10.92	9.18	7.98	7.98
	9	12.54	9.9	10.57	8.96	7.87	7.87
	8	12.05	9.59	10.15	8.68	7.72	7.72
180	10	14.7	11.51	12.39	10.4	9.13	9.13
	9	14.2	11.2	11.95	10.12	8.99	8.99
	8	13.61	10.82	11.44	9.78	8.81	8.81
200	12	16.32	12.78	13.76	11.55	10.02	10.02
	11	15.91	12.52	13.4	11.32	9.91	9.91
	10	15.43	12.22	12.99	11.05	9.77	9.77

Unit Size (at High Speed)	Water Flow Rate (GPM)	Intering Water °F (°C)		
		140 (60)	149 (65)	158 (70)
		Capacity (KW)		
060	4	6.65	7.49	8.34
	3.5	6.53	7.36	8.2
	3	6.37	7.19	8
080	4.5	8.03	9.05	10.08
	4	7.89	8.9	9.91
	3.5	7.71	8.7	9.7
100	6	9.98	11.24	12.51
	5	9.73	10.97	12.22
	4	9.38	10.59	11.8
120	7	11.33	12.76	14.2
	6	11.1	12.51	13.93
	5	10.97	12.17	13.55
140	8	13.87	15.62	17.38
	7	13.64	15.37	17.1
	6	13.34	15.03	16.73
160	10	15.4	17.35	19.3
	9	15.22	17.15	19.08
	8	15	16.91	18.81
180	10	17.77	20.02	22.27
	9	17.55	19.77	21.99
	8	17.28	19.47	21.66
200	12	19.31	21.75	24.19
	11	19.13	21.55	23.97
	10	18.92	21.31	23.71

Cooling design condition; inlet air temp: 24 °C (75 °F) WB= 17 °C (62 °F) , sea level : 4000 ft

Heating design condition; inlet air temp: 20 °C (68 °F) , sea level : 4000 ft

TC : Total Cooling Capacity

SHC : Sensible Capacity

Cooling Mode

Unit Size (at High Speed)	Water Flow Rate (GPM)	Saturated Temperature Leaving Evaporator °F (°C)					
		41 (5)		45 (7)		50 (10)	
		Capacity (KW)					
		TC	SHC	TC	SHC	TC	SHC
060	4	6.63	4.36	5.82	3.99	4.55	3.43
	3.5	6.28	4.17	5.51	3.82	4.3	3.28
	3	5.84	3.92	5.12	3.59	3.99	3.09
080	4.5	7.89	5.29	6.92	4.84	5.39	4.16
	4	7.5	5.06	6.57	4.64	5.11	3.99
	3.5	7.03	4.79	6.15	4.39	4.78	3.78
100	6	10.21	6.8	8.95	6.22	6.97	5.35
	5	9.51	6.41	8.33	5.87	6.47	5.04
	4	8.57	5.87	7.5	5.38	5.81	4.62
120	7	11.67	7.84	10.23	7.18	7.96	6.17
	6	11.02	7.47	9.65	6.84	7.5	5.88
	5	10.18	6.99	8.91	6.4	6.91	5.5
140	8	14.46	9.62	12.67	8.79	9.85	7.55
	7	13.78	9.24	12.06	8.45	9.36	7.25
	6	12.94	8.76	11.31	8.01	8.76	6.87
160	10	16.51	10.98	14.47	10.05	11.27	8.63
	9	15.97	10.68	13.99	9.77	10.88	8.39
	8	15.32	10.31	13.41	9.43	10.41	8.1
180	10	18.75	12.46	16.42	11.39	12.77	9.76
	9	18.09	12.08	15.82	11.04	12.28	9.47
	8	17.29	11.64	15.11	10.63	11.71	9.11
200	12	20.84	13.84	18.26	12.66	14.21	10.86
	11	20.29	13.53	17.77	12.37	13.81	10.62
	10	19.65	13.17	17.19	12.04	13.34	10.33

Cooling design condition; inlet air temp: 27 °C (80 °F) WB= 19 °C (67 °F) , sea level : 4000 ft

Heating design condition; inlet air temp: 24 °C (75 °F) , sea level : 4000 ft

TC : Total Cooling Capacity

SHC : Sensible Capacity

Heating Mode

Unit Size (at High Speed)	Water Flow Rate (GPM)	Intering Water °F (°C)		
		140 (60)	149 (65)	158 (70)
		Capacity (KW)		
060	4	5.98	6.82	7.66
	3.5	5.87	6.7	7.53
	3	5.73	6.54	7.36
080	4.5	7.23	8.24	9.27
	4	7.1	8.1	9.11
	3.5	6.94	7.93	8.92
100	6	8.98	10.24	11.5
	5	8.76	9.99	11.23
	4	8.45	9.64	10.84
120	7	10.19	11.63	13.06
	6	9.99	11.4	12.81
	5	9.72	11.09	12.46
140	8	12.48	14.23	15.98
	7	12.27	14	15.72
	6	12	13.7	15.39
160	10	13.86	15.8	17.74
	9	13.7	15.62	17.54
	8	13.51	15.4	17.3
180	10	16	18.23	20.47
	9	15.8	18	20.22
	8	15.56	17.73	19.92
200	12	17.38	19.81	22.24
	11	17.22	19.63	22.04
	10	17.03	19.41	21.8

Cooling Mode

Unit Size (at High Speed)	Water Flow Rate (GPM)	Saturated Temperature Leaving Evaporator °F (°C)					
		41 (5)		45 (7)		50 (10)	
		Capacity (KW)					
		TC	SHC	TC	SHC	TC	SHC
		8.28	4.72	7.45	4.36	6.15	3.81
		7.83	4.5	7.04	4.15	5.8	3.63
		7.27	4.22	6.54	3.89	5.38	3.4
	3.5	9.83	5.69	8.83	5.25	7.27	4.59
		9.33	5.43	8.38	5.02	6.89	4.38
		8.74	5.13	7.84	4.74	6.44	4.14
100	6	12.72	7.33	11.43	6.76	9.41	5.91
	5	11.83	6.88	10.62	6.35	8.72	5.54
	4	10.65	6.26	9.54	5.78	7.81	5.04
120	7	14.55	8.43	13.07	7.78	10.75	6.8
	6	13.71	8	12.31	7.39	10.1	6.45
	5	12.65	7.45	11.34	6.88	9.29	6
140	8	18.01	10.36	16.18	9.56	13.3	8.33
	7	17.15	9.93	15.39	9.15	12.62	7.97
	6	16.07	9.38	14.4	8.64	11.78	7.52
160	10	20.58	11.84	18.5	10.93	15.23	9.54
	9	19.89	11.49	17.86	10.6	14.68	9.25
	8	19.07	11.07	17.1	10.21	14.03	8.9
180	10	23.37	13.43	20.97	12.37	17.23	10.78
	9	22.51	13	20.18	11.97	16.55	10.42
	8	21.49	12.48	19.25	11.49	15.75	10
200	12	25.98	14.93	23.34	13.77	19.2	12.01
	11	25.28	14.58	22.68	13.43	18.64	11.71
	10	24.45	14.16	21.93	13.05	17.99	11.37

Heating Mode

Unit Size (at High Speed)	Water Flow Rate (GPM)	Intering Water °F (°C)		
		140 (60)	149 (65)	158 (70)
		Capacity (KW)		
060	4	5.5	6.34	7.18
	3.5	5.41	6.23	7.06
	3	5.28	6.09	6.9
080	4.5	6.65	7.67	8.69
	4	6.54	7.54	8.54
	3.5	6.4	7.38	8.36
100	6	8.27	9.53	10.8
	5	8.07	9.3	10.53
	4	7.78	8.97	10.17
120	7	9.39	10.82	12.25
	6	9.2	10.61	12
	5	8.95	10.32	11.69
140	8	11.49	13.24	14.98
	7	11.31	13.02	14.74
	6	11.06	12.74	14.43
160	10	12.77	14.7	16.64
	9	12.62	14.53	16.45
	8	12.44	14.33	16.22
180	10	14.73	16.96	19.19
	9	14.55	16.75	18.96
	8	14.33	16.5	18.68
200	12	16	18.43	20.85
	11	15.86	18.26	20.66
	10	15.69	18.06	20.44

Cooling design condition; inlet air temp: 29 °C (85 °F) WB= 22 °C (72 °F), sea level : 4000 ft

Heating design condition; inlet air temp: 27 °C (80 °F), sea level : 4000 ft

TC : Total Cooling Capacity

SHC : Sensible Capacity

Dimensions

ACLAXXL2

[unit : mm]

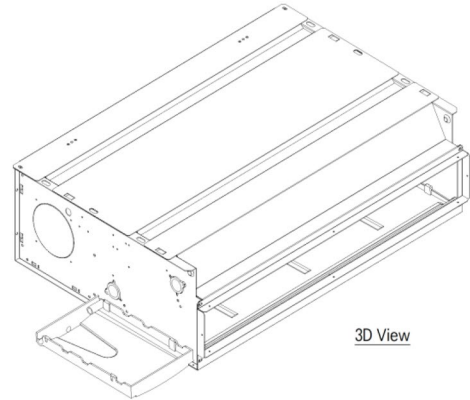
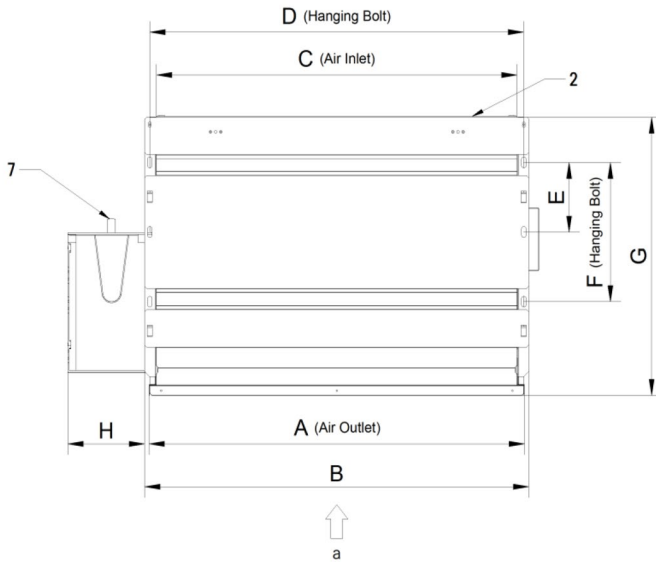

3D View

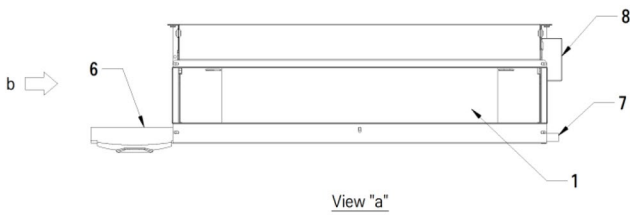

View "a"

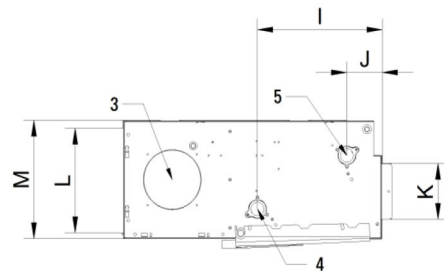

View "b"

Note :

1. Unit should be installed in compliance with the instructions in the product box.
2. Inlet/outlet pipes connection side can be selected by the customer.

Unit Model	A	B	C	D	E	F	G	H	I	J	K	L	M
ACLA020L2	628	645	600	625	130	260	520	150	180	85	105	195	220
ACLA030L2	728	745	700	725	130	260	520	150	180	85	105	195	220
ACLA040L2	828	845	800	825	130	260	520	150	180	85	105	195	220
ACLA060L2	928	945	900	925	130	260	520	150	180	85	105	195	220
ACLA080L2	1178	1195	1150	1175	130	260	520	150	180	85	105	195	220
ACLA100L2	1428	1445	1400	1425	130	260	520	150	180	85	105	195	220

No.	Part Name
1	Air outlet
2	Air intake
3	Fresh air intake hole
4	Inlet chilled water pipe connection
5	Outlet chilled water pipe connection
6	External drain pan (optional accessory)
7	Drain pipe connection
8	Electrical box

ACLSXXXL2

[unit : mm]

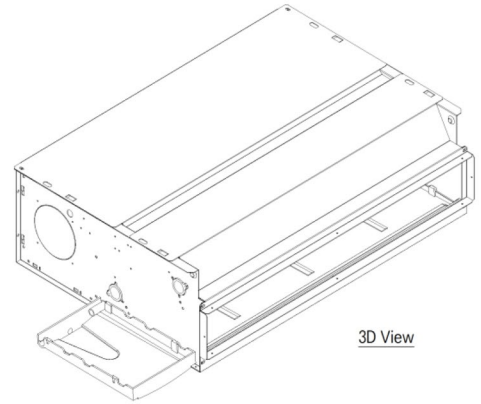
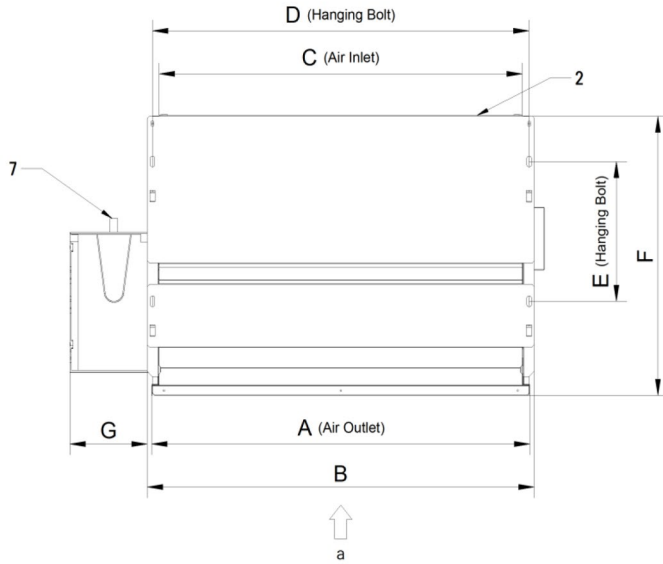

3D View

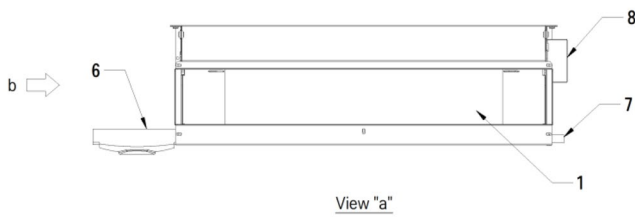

View "a"

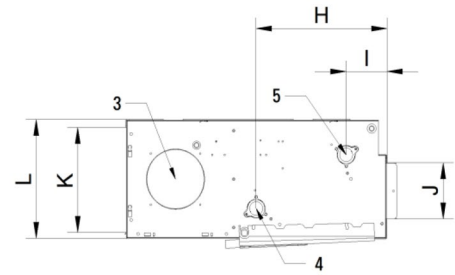

View "b"

Note :

- 1. Unit should be installed in compliance with the instructions in the product box.
- 2. Inlet/outlet pipes connection side can be selected by the customer.

Unit Model	A	B	C	D	E	F	G	H	I	J	K	L
ACLS020L2	628	645	600	625	260	520	150	220	110	105	155	180
ACLS030L2	728	745	700	725	260	520	150	220	110	105	155	180
ACLS040L2	828	845	800	825	260	520	150	220	110	105	155	180
ACLS060L2	928	945	900	925	260	520	150	220	110	105	155	180
ACLS080L2	1178	1195	1150	1175	260	520	150	220	110	105	155	180
ACLS100L2	1428	1445	1400	1425	260	520	150	220	110	105	155	180

No.	Part Name
1	Air outlet
2	Air intake
3	Fresh air intake hole
4	Inlet chilled water pipe connection
5	Outlet chilled water pipe connection
6	External drain pan (optional accessory)
7	Drain pipe connection
8	Electrical box

[unit : mm]

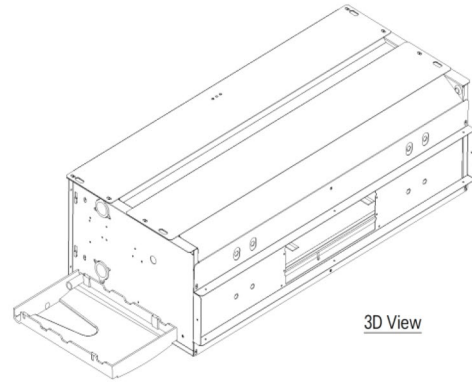
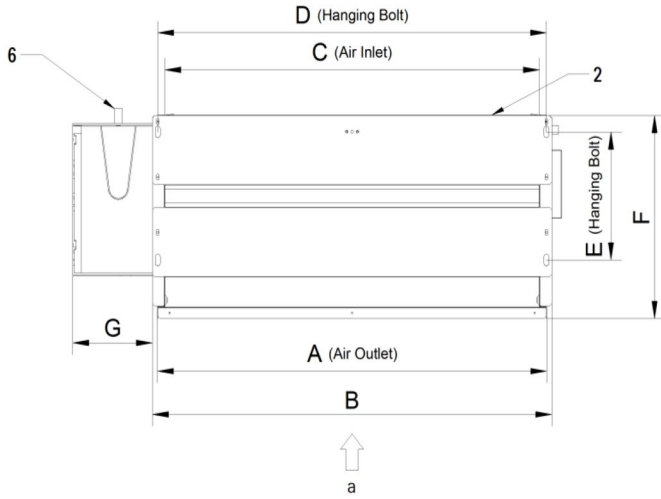

3D View

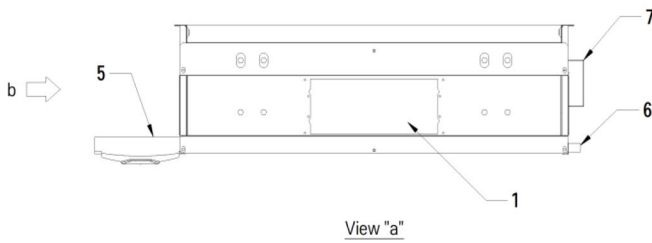

View "a"

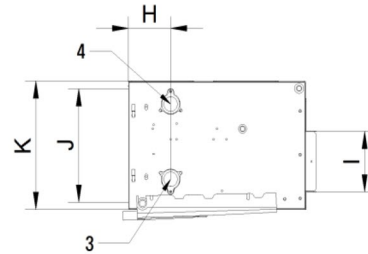

View "b"

Note :

1. Unit should be installed in compliance with the instructions in the product box.
2. Inlet/outlet pipes connection side can be selected by the customer.

Unit Model	A	B	C	D	E	F	G	H	I	J	K
ACMP020L2	628	645	600	625	220	350	150	78	105	195	220
ACMP030L2	728	745	700	725	220	350	150	78	105	195	220
ACMP040L2	828	845	800	825	220	350	150	78	105	195	220
ACMP060L2	928	945	900	925	220	350	150	78	105	195	220
ACMP080L2	1178	1195	1150	1175	220	350	150	78	105	195	220
ACMP100L2	1428	1445	1400	1425	220	350	150	78	105	195	220

No.	Part Name
1	Air outlet
2	Air intake
3	Inlet chilled water pipe connection
4	Outlet chilled water pipe connection
5	External drain pan (optional accessory)
6	Drain pipe connection
7	Electrical box

[unit : mm]

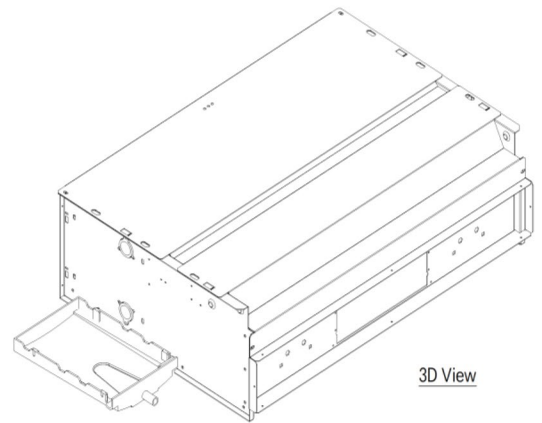
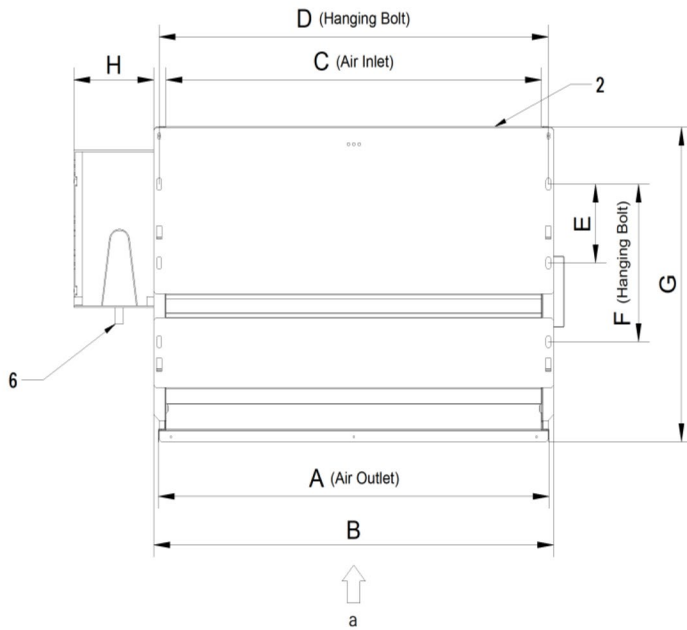

3D View

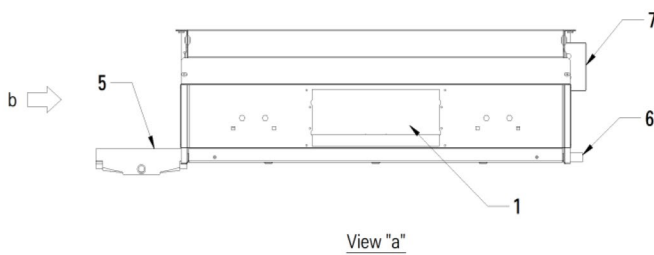

View "a"

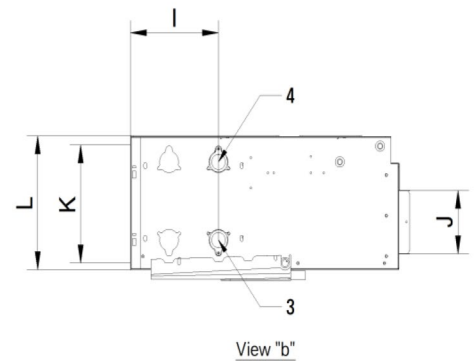

View "b"

Note :

1. Unit should be installed in compliance with the instructions in the product box.
2. Inlet/outlet pipes connection side can be selected by the customer.

Unit Model	A	B	C	D	E	F	G	H	I	J	K	L
ACMH020L2	628	645	600	625	130	260	520	150	164	105	195	220
ACMH030L2	728	745	700	725	130	260	520	150	164	105	195	220

No.	Part Name
1	Air outlet
2	Air intake
3	Inlet chilled water pipe connection
4	Outlet chilled water pipe connection
5	External drain pan (optional accessory)
6	Drain pipe connection
7	Electrical box

ACMH040L2 / ACMH060L2 / ACMH080L2 / ACMH100L2

[unit : mm]

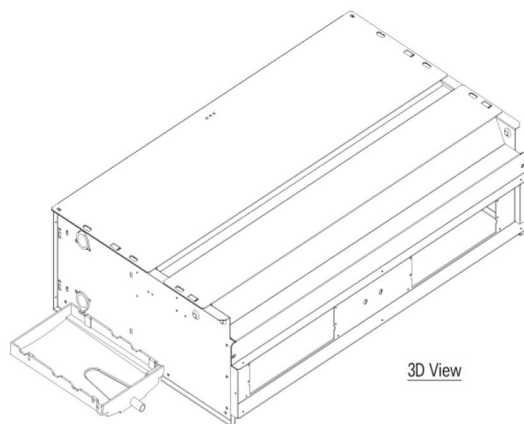
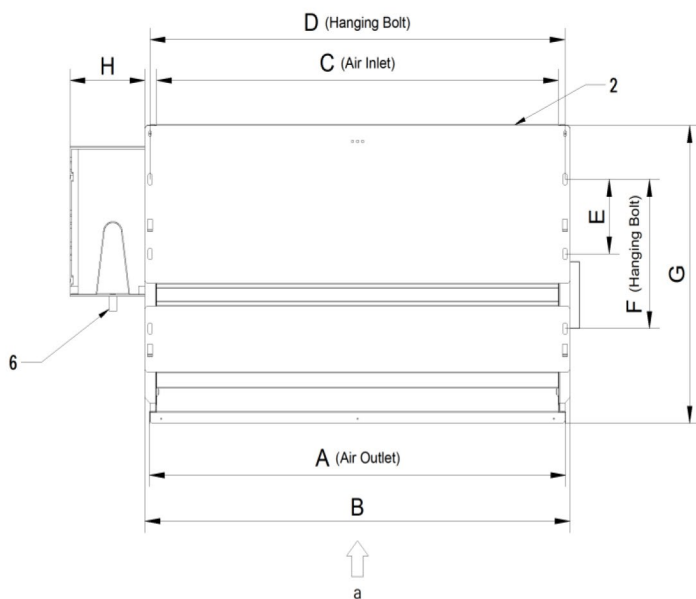

3D View

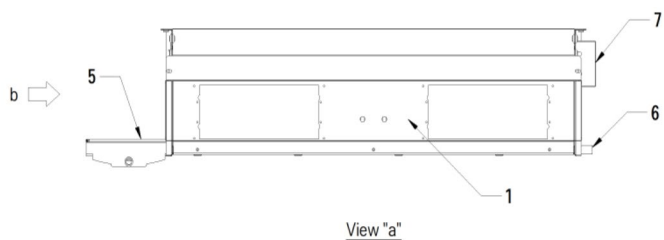

View "a"

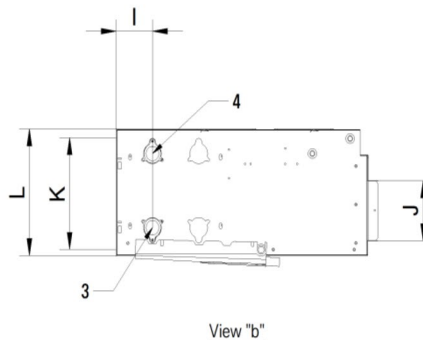

View "b"

Note :

1. Unit should be installed in compliance with the instructions in the product box.
2. Inlet/outlet pipes connection side can be selected by the customer.

Unit Model	A	B	C	D	E	F	G	H	I	J	K	L
ACMH040L2	828	845	800	825	130	260	520	150	72	105	195	220
ACMH060L2	928	945	900	925	130	260	520	150	72	105	195	220
ACMH080L2	1178	1195	1150	1175	130	260	520	150	72	105	195	220
ACMH100L2	1428	1445	1400	1425	130	260	520	150	72	105	195	220

No.	Part Name
1	Air outlet
2	Air intake
3	Inlet chilled water pipe connection
4	Outlet chilled water pipe connection
5	External drain pan (optional accessory)
6	Drain pipe connection
7	Electrical box

ACMHXXXL4

[unit : mm]

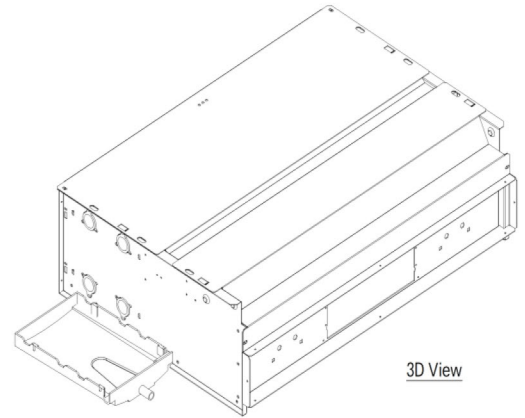
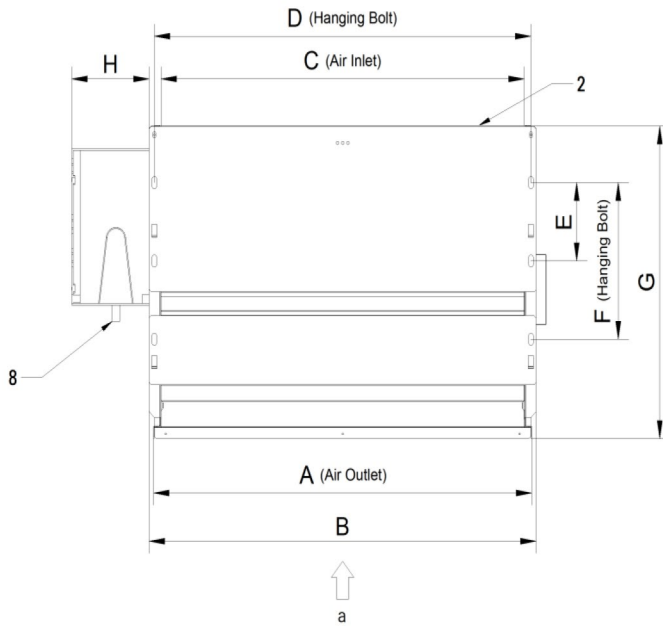

3D View

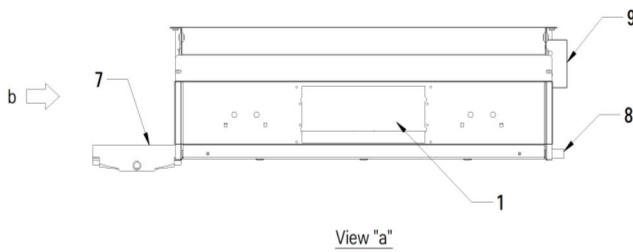

View "a"

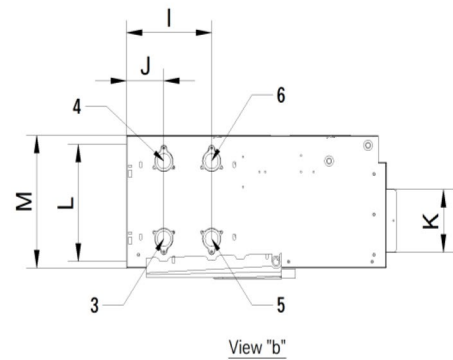

View "b"

Note :

1. Unit should be installed in compliance with the instructions in the product box.
2. Inlet/outlet pipes connection side can be selected by the customer.

Unit Model	A	B	C	D	E	F	G	H	I	J	K	L	M
ACMH020L4	628	645	600	625	130	260	520	150	164	72	105	195	220
ACMH030L4	728	745	700	725	130	260	520	150	164	72	105	195	220
ACMH040L4	828	845	800	825	130	260	520	150	164	72	105	195	220
ACMH060L4	928	945	900	925	130	260	520	150	164	72	105	195	220
ACMH080L4	1178	1195	1150	1175	130	260	520	150	164	72	105	195	220
ACMH100L4	1428	1445	1400	1425	130	260	520	150	164	72	105	195	220

No.	Part Name
1	Air outlet
2	Air intake
3	Inlet hot water pipe connection
4	Outlet hot water pipe connection
5	Inlet chilled water pipe connection
6	Outlet chilled water pipe connection
7	External drain pan (optional accessory)
8	Drain pipe connection
9	Electrical box

ACHAXXL2

[unit : mm]

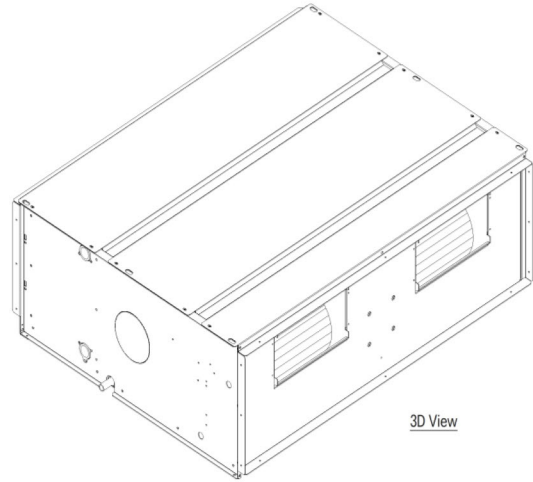
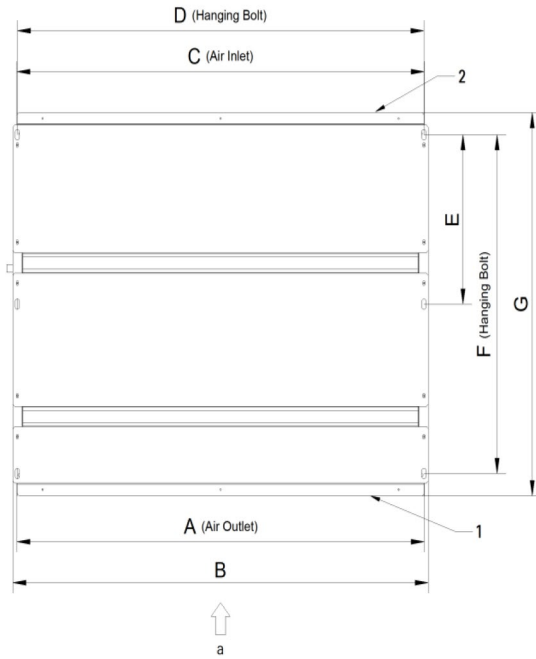

3D View

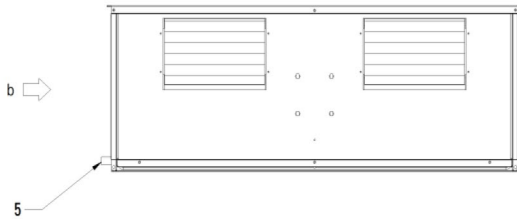

View "a"

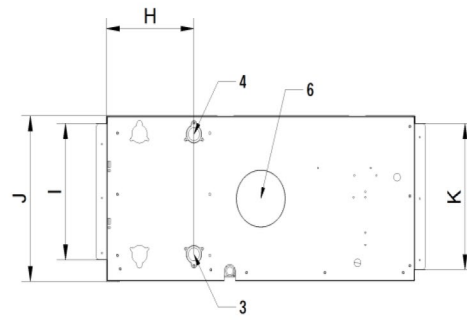

View "b"

Unit Model	A	B	C	D	E	F	G	H	I	J	K
ACHA060L2	827	845	827	825	330	662	750	200	268	320	288
ACHA080L2	827	845	827	825	330	662	750	200	268	320	288
ACHA100L2	927	945	927	925	330	662	750	200	268	320	288
ACHA120L2	927	945	927	925	330	662	750	200	268	320	288
ACHA140L2	1177	1195	1177	1175	330	662	750	200	268	320	288
ACHA160L2	1177	1195	1177	1175	330	662	750	200	268	320	288
ACHA180L2	1427	1445	1427	1425	330	662	750	200	268	320	288
ACHA200L2	1427	1445	1427	1425	330	662	750	200	268	320	288

Note :
 1. Unit should be installed in compliance with the instructions in the product box.
 2. Inlet/outlet pipes connection side can be selected by the customer.

No.	Part Name
1	Air outlet
2	Air intake
3	Inlet chilled water pipe connection
4	Outlet chilled water pipe connection
5	Drain pipe connection
6	Fresh air intake hole

ACHAXXL4

[unit : mm]

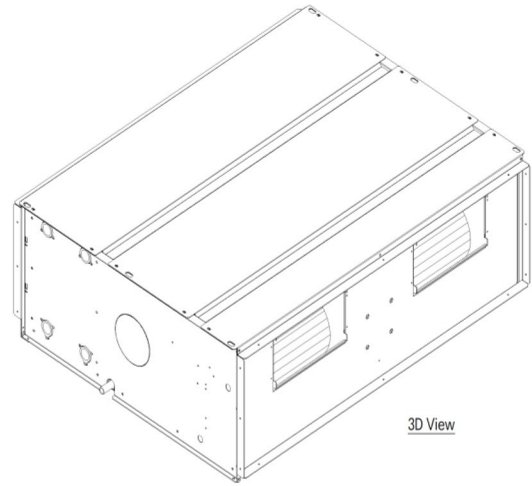
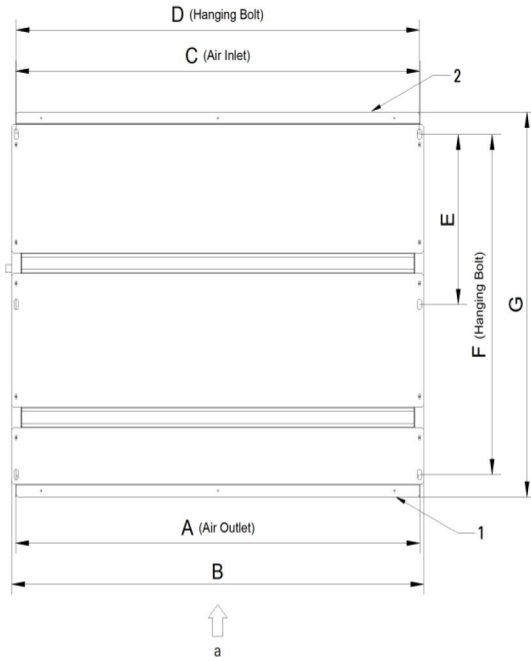

3D View

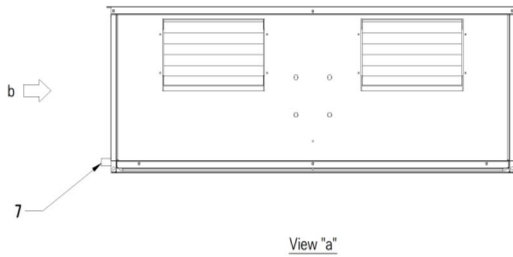

View "a"

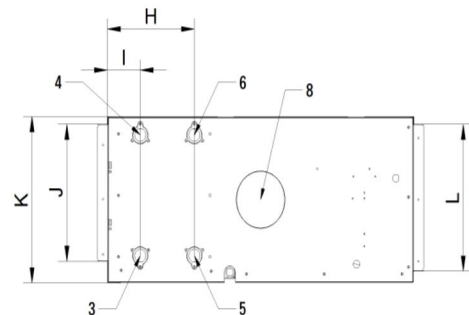

View "b"

Unit Model	A	B	C	D	E	F	G	H	I	J	K	L
ACHA060L4	827	845	827	825	330	662	750	200	75	268	320	288
ACHA080L4	827	845	827	825	330	662	750	200	75	268	320	288
ACHA100L4	927	945	927	925	330	662	750	200	75	268	320	288
ACHA120L4	927	945	927	925	330	662	750	200	75	268	320	288
ACHA140L4	1177	1195	1177	1175	330	662	750	200	75	268	320	288
ACHA160L4	1177	1195	1177	1175	330	662	750	200	75	268	320	288
ACHA180L4	1427	1445	1427	1425	330	662	750	200	75	268	320	288
ACHA200L4	1427	1445	1427	1425	330	662	750	200	75	268	320	288

Note :

1. Unit should be installed in compliance with the instructions in the product box.
2. Inlet/outlet pipes connection side can be selected by the customer.

No.	Part Name
1	Air outlet
2	Air intake
3	Inlet hot water pipe connection
4	Outlet hot water pipe connection
5	Inlet chilled water pipe connection
6	Outlet chilled water pipe connection
7	Drain pipe connection
8	Fresh air intake hole

ACSVXXXL2

[unit : mm]

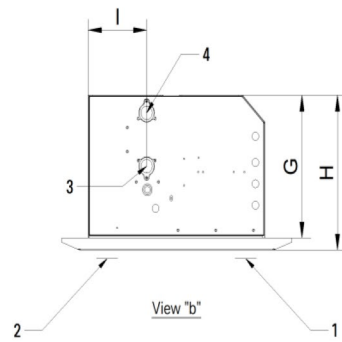
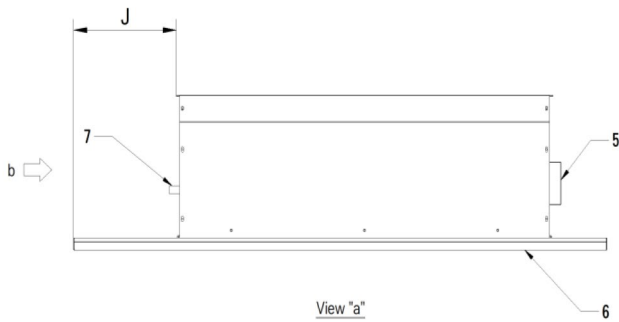
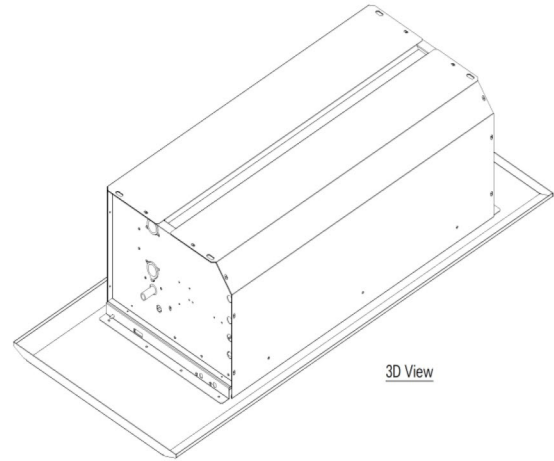
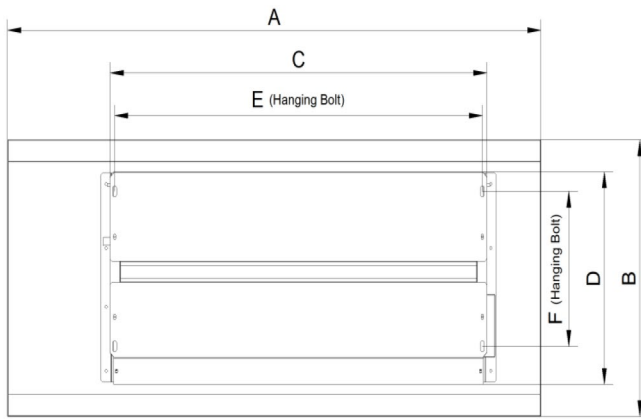

Unit Model	A	B	C	D	E	F	G	H	I	J
ACSV020L2	1000	520	650	400	630	290	270	290	130	230
ACSV030L2	1100	520	750	400	730	290	270	290	130	230
ACSV040L2	1200	520	850	400	830	290	270	290	130	230
ACSV060L2	1300	520	950	400	930	290	270	290	130	230
ACSV080L2	1550	520	1200	400	1180	290	270	290	130	230
ACSV100L2	1800	520	1450	400	1430	290	270	290	130	230

Note :

1. Unit should be installed in compliance with the instructions in the product box.
2. Inlet/outlet pipes connection side can be selected by the customer.

No.	Part Name
1	Air outlet
2	Air intake
3	Inlet chilled water pipe connection
4	Outlet chilled water pipe connection
5	Electrical box
6	Decoration panel
7	Drain pipe connection

AFSCXXXL2

[unit : mm]

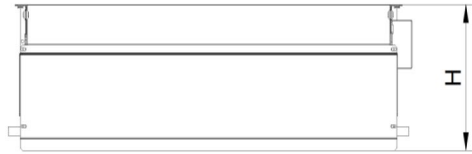

a

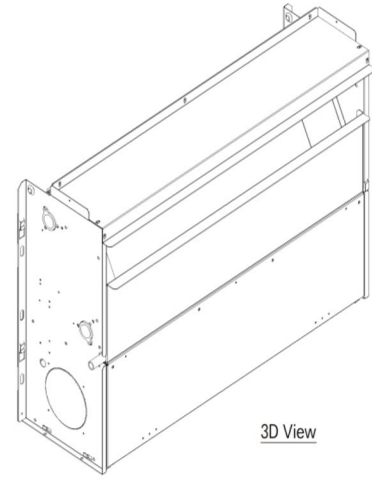

3D View

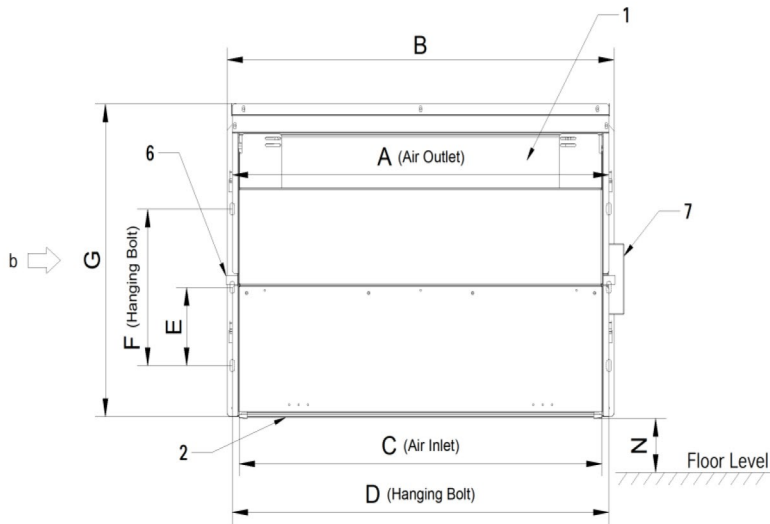

View "a"

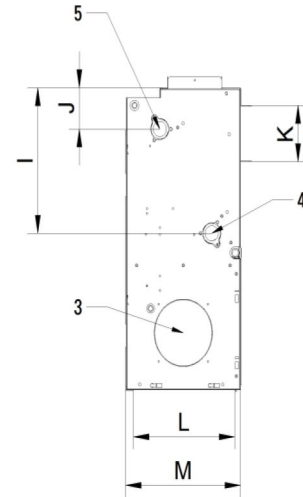

View "b"

Note :

1. Unit should be installed in compliance with the instructions in the product box.
2. Inlet/outlet pipes connection side can be selected by the customer.

Unit Model	A	B	C	D	E	F	G	H	I	J	K	L	M	N (min)
ACLA020L2	628	645	600	625	130	260	520	242	180	85	93	195	220	80
ACLA030L2	728	745	700	725	130	260	520	242	180	85	93	195	220	80
ACLA040L2	828	845	800	825	130	260	520	242	180	85	93	195	220	100
ACLA060L2	928	945	900	925	130	260	520	242	180	85	93	195	220	100
ACLA080L2	1178	1195	1150	1175	130	260	520	242	180	85	93	195	220	100
ACLA100L2	1428	1445	1400	1425	130	260	520	242	180	85	93	195	220	100

No.	Part Name
1	Air outlet
2	Air intake
3	Fresh air intake hole
4	Inlet chilled water pipe connection
5	Outlet chilled water pipe connection
6	Drain pipe connection
7	Electrical box

AFSGXXL2

[unit : mm]

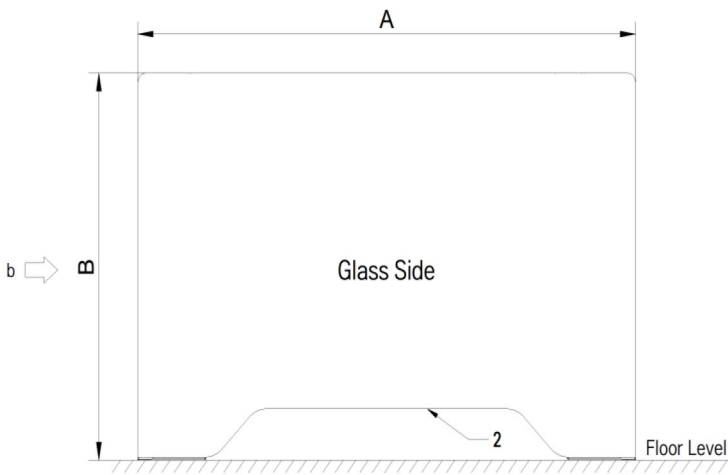
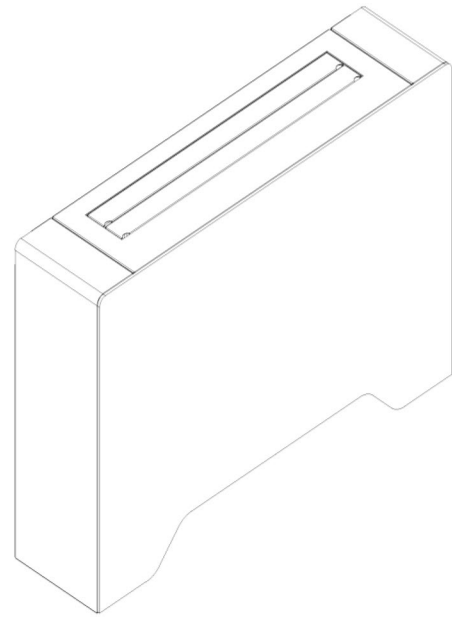
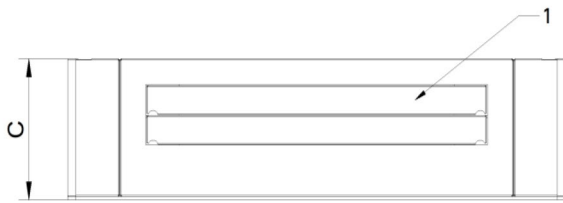

View "a"

Installation Side →



View "b"

Unit Model	A	B	C
ACLA020L2	865	640	233
ACLA030L2	965	640	233
ACLA040L2	1065	640	233
ACLA060L2	1165	640	233
ACLA080L2	1415	640	233
ACLA100L2	1665	640	233

Note :
 1. Unit should be installed in compliance with the instructions in the product box.
 2. Inlet/outlet pipes connection side can be selected by the customer.

No.	Part Name
1	Air outlet vane
2	Air intake

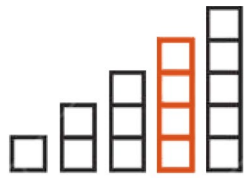

Accessories

Transition Fitting

Rectangular to Round

- For supply air
- Suitable for ACLA, ACLS, ACMP, ACMH models



90 Deg. Elbow

- For supply air
- Suitable for ACLA, ACLS, ACMP, ACMH models



Fish Gill

- For reducing noise level caused by return air
- Suitable for ACLA, ACMP, ACMH models



Air Intake Hole Connection

- Suitable for ACLA, ACMP, ACMH models



Installation Equipment

Mounting Support

- Well-advised for easy and safe installation
- Suitable for all models



External Drain Pan

- Preventing unexpected leakage
- Suitable for ACLA, ACLS, ACMP, ACMH models



Aluminum Filter

- For return air instead of polypropylene filter
- Suitable for all except CS and CHA models





بادبان تهویه پارسیان

دفتر مرکزی تهران

تهران . پاسداران . برج سفید . واحد ۸۰۴

۲۲ ۵۸ ۱۸ ۲۱